

# **EXHIBITOR MANUAL**

## **– Regulations –**

**■ Manufacturing World Nagoya 2026**

**Built by**



In the business of  
building businesses

**Dates: April 8 (Wed) – 10 (Fri), 2026**

**Venue: Port Messe Nagoya, Japan**

**Organised by: RX Japan GK**

# Table of Content

Content	Page
<b>I. Basic Information of Exhibition Venue.....</b>	<b>3</b>
● Port Messe Nagoya Facility Guide.....	3
● Access .....	3
● Show Schedule .....	4
● Rules and On-site Regulations .....	5
● Sound Level and Prohibited Activities.....	7
<b>II. Move-in/out .....</b>	<b>8</b>
● Cautions for Move-in/out of Exhibits .....	8
● Visitation of Minors in the Pavilion .....	9
● Procedures about Entry to the Hall.....	9
<b>III. Regulations and Applications for Booth Construction .....</b>	<b>10</b>
● Regulations and Applications for Booth Construction.....	10
● Regulations for Booth Construction .....	11
● Inquiries Regarding PIT Plan.....	13
● Fire Regulations.....	14
● Notes and Precautions .....	15
● Removal of Trash .....	15
● No Smoking .....	15
● Floor Construction Regulations.....	16
● Electricity.....	17
● Water Supply .....	17
● Compressed Air Supply .....	17
● Handling Fire and Dangerous Materials for Exhibits and Demonstration.....	18
● Carrying-in/Demonstration of Hydrogen .....	19
● Ceiling Structure .....	20
● Protection of Industrial Property Rights .....	21
● About the Use of Personal Information .....	21
<b>Details of Rental Display System .....</b>	<b>22</b>
● Panel Display Type / Pavilion Booth Type.....	43

## I. Basic Information of Exhibition Venue

### ● Port Messe Nagoya Facility Guide

Please check from the URL below:

◆ <https://portmesse.com/en/facility-en/>

### ● Access

Please check from the URL below:

◆ <https://portmesse.com/en/access-en/>

**● Show Schedule**

DATE	SCHEDULE	Time permitted for VEHICLES
<b>April 6</b> <b>(Mon)</b> <div style="border: 1px solid black; padding: 2px; width: fit-content;">Move-in</div>	<p style="text-align: center;"><b>8:00am–8:00pm</b>  <b>Move-in and Booth Construction</b></p> <p>*Exhibitors (including your own booth contractors) who wish to work overtime during 8:00pm-10:00pm are required to submit an application form at the on-site Show Management Office. (Free)                      *No overtime work is allowed after 10:00pm for security reasons.</p>	<p style="text-align: center;"><b>8:00am–8:00pm</b></p> <p>*Vehicle Pass is required for every vehicle that will enter / exit the exhibition halls.</p>
<b>April 7</b> <b>(Tue)</b> <div style="border: 1px solid black; padding: 2px; width: fit-content;">Move-in</div>	<p style="text-align: center;"><b>8:00am–1:00pm</b>  <b>Move-in and Booth Construction</b></p> <p style="text-align: center;"><b>1:00pm–8:00pm</b>  <b>Exhibits Move-in (hand-carry only)</b></p> <p>*Exhibitors (including your own booth contractors) who wish to work overtime during 8:00pm-10:00pm are required to submit an application form at the on-site Show Management Office. (Free)                      *No overtime work is allowed after 10:00pm for security reasons.</p>	<p style="text-align: center;"><b>8:00am–1:00pm</b></p> <p>*Vehicle Pass is required for every vehicle that will enter/exit the exhibition halls.                      *No vehicles are allowed to enter the halls after <b>1:00pm</b>.</p>
<b>April 8</b> <b>(Wed)</b> <div style="border: 1px solid black; padding: 2px; width: fit-content;">Exhibition</div>	<p style="text-align: center;"><b>8:00am–10:00am</b>  <b>Doors Open for Exhibitors</b>                      (preparation for the show)</p> <hr style="border-top: 1px dashed black;"/> <p style="text-align: center;"><b>10:00am–5:00pm</b>  <b>Show Hours</b>                      [No overtime work is allowed.]</p>	
<b>April 9</b> <b>(Thu)</b> <div style="border: 1px solid black; padding: 2px; width: fit-content;">Exhibition</div>	<p style="text-align: center;"><b>8:30am–10:00am</b>  <b>Doors Open for Exhibitors</b>                      (preparation for the show)</p> <p>*If the exhibitors wish to enter the hall before 8:30am, please come to the on-site Show Management Office.</p> <hr style="border-top: 1px dashed black;"/> <p style="text-align: center;"><b>10:00am–5:00pm</b>  <b>Show Hours</b>                      [No overtime work is allowed.]</p>	<p>*No vehicles are allowed to enter the halls. (hand carry only)</p>
<b>April 10</b> <b>(Fri)</b> <div style="border: 1px solid black; padding: 2px; width: fit-content;">Exhibition</div> <div style="border: 1px solid black; padding: 2px; width: fit-content;">Move-out</div>	<p style="text-align: center;"><b>8:30am–10:00am</b>  <b>Doors Open for Exhibitors</b>                      (preparation for the show)</p> <p>*If the exhibitors wish to enter the hall before 8:30am, please come to the on-site Show Management Office.</p> <hr style="border-top: 1px dashed black;"/> <p style="text-align: center;"><b>10:00am–5:00pm</b>  <b>Show Hours</b></p> <hr style="border-top: 1px dashed black;"/> <p style="text-align: center;"><b>5:00pm–6:00pm</b>  <b>Packing and hand-carry loading only</b></p> <p style="text-align: center;"><b>6:00pm–10:00pm</b>  <b>Dismantling/Move-out</b></p>	<p style="text-align: center;"><b>6:00am–10:00pm</b></p> <p>*Security guard on site will conduct vehicles showing the screen of "E-Ticket for Priority Move-out of Exhibits" preferentially to the gates.</p> <p>*For the vehicles loading exhibits, please show the screen of "E-Ticket for Priority Move-out of Exhibits" (one vehicle entry per booth).                      *Vehicles are allowed to enter the halls only after 6:00pm. Until then, please keep out of the halls and follow the instructions of on-site security guards.                      *Vehicle Pass and numbered ticket issued from waiting spot are required for every vehicle that enters / exits the exhibition halls.</p>

**Note:**

- No vehicles are allowed to enter the halls after **1:00pm on the second day of move-in**. Be sure to finish moving in all the large machinery/luggage before **1:00pm**.
- Removal of exhibits and dismantling of stands are strictly prohibited before **5:00pm on the last day of the show**.
- All displays must be dismantled and completely evacuated before **10:00pm on the last day of the show**. In case of overtime work is arose, additional cost for overall exhibition halls will be charged on the exhibitor.
- Be careful for any possible accidents while moving out. Booth dismantling takes place simultaneously for all exhibitors.
- Keep your PCs, business cards and other valuables safe and secure on your own responsibility.

## ● Rules and On-site Regulations

### 1) **Attending Your Booth**

You MUST assign at least one staff at your booth all times during the exhibition. The following acts are strictly prohibited as they project unprofessional images:

- **coming late/leaving early**
- **packing/carrying out exhibits during the show hours**
- **leaving your booth unattended**

Make sure to be at your booth during the entire show period.

### 2) **Obligation to Provide a Privacy Policy**

If you plan to collect personal information at the exhibition venue, please display a sign with your company's privacy policy or ensure that you are prepared to provide it upon request.

### 3) **No Smoking**

Port Messe Nagoya is a non-smoking venue. Smoking in the exhibition halls, including inside your own booths, is prohibited for the entire show period as well as move-in/out days. It is only permitted in designated smoking areas outside the building. Make sure that your contractors as well as your own staff do not smoke. They may be asked to leave the halls if they are found smoking inside the building.

### 4) **No Photography/Filming/Video-taking**

Only the official photographers and accredited press, wearing press badges issued by Show Management, will be permitted to film or to take photographs/videos in the exhibition halls. All photography, filming and video-taking outside your own booth is strictly prohibited. Contact Show Management if you need to take photos or videos for business purpose. When you are asked for press interviews, your cooperation would be deeply appreciated.

### 5) **No Sales Activities Outside Your Booth**

Sales activities (such as handing out pamphlets and questionnaire, etc.) are permitted only inside your booth. Placing them outside your booth (hall entrance/exit) without permission of Show Management is prohibited.

### 6) **Preventing Accidents caused by Demonstrations**

Be sure to take precautions against any damage, loss, fire disaster, etc. that may be caused by demonstrations. Make sure that beam, hot air, dust, gas, odor, vibration, etc. from your booth do not harm other exhibitors.

### 7) **Responsibility for Exhibits and Insurance**

Exhibitors are responsible for securing their own booth, display and products. Neither Show Management, Port Messe Nagoya, the contractors, nor any of their officers/agents/employees are responsible for loss, damage or theft of property.

Exhibitors are strongly advised to insure their exhibits against loss and take every precaution to protect exhibit products and personal belongings. Do not leave expensive items at the booth each night after the show.

### 8) **Copyright**

Show Management has no copyright responsibility in respect of any exhibitors. Exhibitors are reminded that third party copyrights should not be infringed. Should any copyright dispute arise, Show Management may require the exhibitor to make changes in its exhibits.

### 9) **Securing Aisles**

If you hold presentations or demonstrations in your booth, you must keep enough room inside your booth for your audiences and also arrange staff to keep the aisles clear for other visitors.

### 10) **Sampling Food and Drink**

In case of selling or providing food and drink, it is required to consult with the Health Center and Show Management.

### 11) **Demonstration of E-cigarettes**

Demonstrations of e-cigarettes containing harmful substances such as nicotine are prohibited. Yet, it is possible to hold demonstrations of e-cigarettes without harmful substances if certain criteria are fulfilled. If you are considering such demonstrations, please consult with the official contractor.

### 12) **Display of Exhibits which require careful handling such as cutting tools and blades**

Please adhere to the following guidelines.

- Assign a person-in-charge and display the products within his/her visible range.
- Provide guidance to visitors on handling when they pick up the products.
- Ensure that no items are missing during and after the exhibition period.

**13) Demonstration of Exhibits with Lithium-ion Battery Installed**

Application for Handling Dangerous Materials is required if you wish to hold demonstration of exhibits with lithium-ion battery installed (electrical devices excluded). Please submit the application before the deadline.

**14) Exhibiting Heavy Products**

In case of bringing heavy products of total weight 5t or more, additional consultation about placement of exhibits are needed. Please contact Show Management in advance.

**15) Demonstration using Flying Objects**

If you wish to hold demonstration using flying objects, please consult with Show Management.

**16) Bringing and Exhibiting Animals**

Bringing and exhibiting animals in the venue is generally prohibited.

If animals are essential for exhibiting products or services, they may be permitted with prior approval.

For details, please contact Show Management in advance.

\*No prior permission is required for assistance dogs (such as guide dogs, hearing dogs, and service dogs) to enter the venue.

## ● Sound Level and Prohibited Activities

- (1) Sound coming from your booth (including presentations, demonstrations, narration, etc.) must be lower than 70 decibels.**

If you hold demonstrations or presentations inside your booth, be sure to keep the volume lower than 70 decibels measured at 2 meters away from your booth. Show Management will warn you to turn down the volume if you do not comply with the regulation.

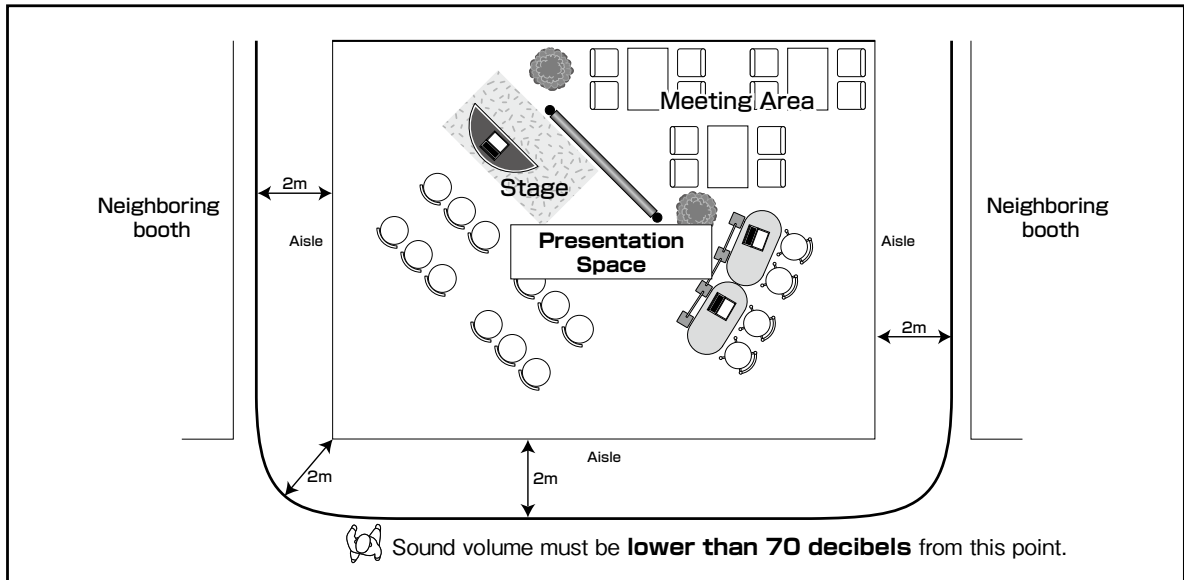

- (2) Place speakers inside your booth at least 1m away from the aisles.**

Setting up speakers within 1 meter from the aisles is prohibited.

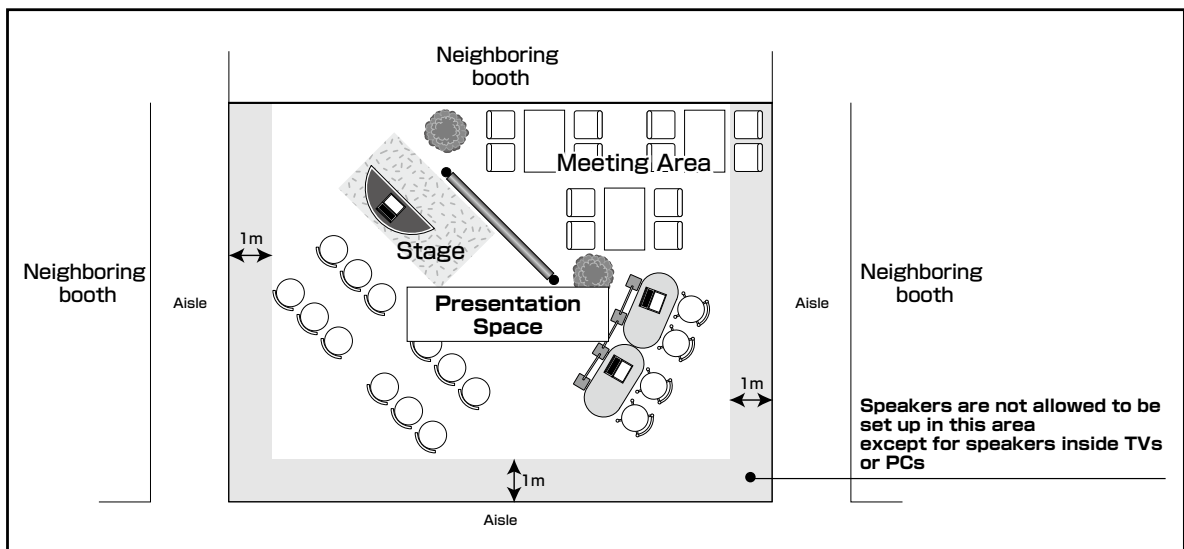

- (3) Lottery (activities such as giving little gifts when someone wins a drawing) is prohibited.**

- (4) The following sales activities are prohibited OUTSIDE your booth.**

- Booth attendees (including booth bunnies) handing out giveaways, questionnaires, etc.
- High-pressure sales by booth attendees (including sales representative).

When Show Management judge that the sales activities outside your booth is disturbing other exhibitors and blocking the passage of visitors, you will be required to stop the sales activities immediately.

- (5) Leading visitors and advertising in a loud voice is prohibited.**

- (6) Blowing bugles, ringing bells, playing instruments and using other noisemakers (megaphone, etc.) are strictly prohibited.**

\*If you go against the regulations above, you may get banned from participating in the show.

## II. Move-in/out

### ● Cautions for Move-in/out of Exhibits

- 1) For exhibits from abroad, please contact a freight forwarder.
- 2) There is no storage space for empty cases, crates and boxes, and Show Management will not provide any. If you require empty crates/boxes for your move-out, please store them properly. Contact Show Management in advance for storage service.
- 3) It is the exhibitor's responsibility to remove or store all crates, boxes and plywood properly. Any crates, boxes and plywood left after the show will be disposed and its cost will be charged to the exhibitor. Note that disposal of large volume wastes will cost additional fees. Contact the official contractor, if you request for cleaning service.
- 4) **Illegal parking, especially double/triple parking, is not allowed and is subject to heavy penalty. This applies to all exhibitors as well as contractors. Kindly advise your contractors and staff.**
- 5) If exhibits are delivered to the booth directly by vehicles, please confirm the width of the aisles in advance.
- 6) Delivery companies such as DHL, FedEx, OCS, TNT, etc. do not require Exhibitor Badges nor Vehicle Passes. They will receive instructions from security guards for the route to the exhibition halls.
- 7) **Removal of any materials including exhibits/decoration is permitted only after the show. Even partial removal of stands is strictly prohibited during the show period.**
- 8) Evacuate all exhibits and booth materials during the period of Dismantle and Move-out. Show Management will dispose or remove all the exhibits and booth materials found in the exhibition halls after the period of Dismantle and Move-out ends. Show Management takes no responsibility for any damages or loss arising from the disposal or removal. Please check the Show Schedule for the duration of Dismantle and Move-out. The cost incurred during the disposal or removal may be charged to the exhibitor.
- 9) Specify the time of delivery when sending the parcels and make sure there is a recipient at the booth during the selected timeslot. If you send parcels of exhibits or publication materials directly to the booth, please indicate your booth number, company name and name of the person in charge on the shipping label clearly. Show Management cannot receive nor keep the parcels on your behalf.
- 10) Vehicle Passes
  - "Vehicle Passes" are required for all vehicles to enter the exhibition halls during the move-in/out period. [Download the pass via Exhibitors Website.](#)
  - No vehicles are permitted to enter the exhibition halls **during the show period**. Exhibits/catalogues/ brochures, etc. must be hand-carried to the exhibition halls from the hall entrances. In this case, parking lots (charged) are available for unloading.
  - "E-Ticket for Priority Move-out of Exhibits" is a pass for preferential entry to the truckyard on the day of move-out in order for loading hand-carry items to the vehicles. One vehicle entry per booth. Vehicles are allowed to enter the halls after an hour from the end of exhibition.
- 11) Regarding to the safety control during move in/out, please confirm to the following regulations.
  - Workers involved in construction should wear helmet, long sleeves, long pants and safety boots.
  - Standing on the top (cap) of step ladder is prohibited. Please lock the step ladder during work.
  - Wear safety harness when working at the height above 2m
  - Refrain from working on any unstable objects like chairs or small boxes.
 Staff from exhibition venue and Show Management, and security guards will carry out inspection during the move-in/out and exhibition period. Please ensure the staff related are familiar with the regulations and prevent any violations.  
 Please be aware that the construction will be suspended if any staff violate the above obligations.

## ● Visitation of Minors in the Pavilion

It is expressly forbidden the entry of minors under 18 (eighteen) years of age, even if accompanied by their guardians, during the periods of Assembly(move-in) and Disassembly(move-out) of the EVENT.

## ● Procedures about Entry to the Hall

### Exhibitor Badges

- Exhibitor Badge is required to enter the exhibition halls during the 3 days of the show. To get Exhibitor Badge, it is required to register all staff who will attend the booth, at Exhibitor Hub before the show. Print and bring the badge.
- Staff under the age of 18 cannot register for Exhibitor Badges. If you have staff members under the age of 18, please contact the Show Management in advance.
- Badges are not required **during move-in and move-out period.**

## III. Regulations and Applications for Booth Construction

### ● Regulations and Applications for Booth Construction

For better preparation, please check with the following list to avoid missing any deadlines.

#### <Must Submit>

For Rental Display System

- Apply via Exhibitors Website

**Click here for Types of Rental Display System**

- Electrical Service Form \*If extra lighting is needed

For Booth Decoration with your own contractor

- Electrical Service Form

#### <Application (Optional)>

- Additional Furniture for Booth Decoration
- Rental Furniture
- Communication Network Service (Internet Connection)
- Visitor Badge Scanner (iPhone Rental Service)
- PC Rental
- AV Equipment Rental
- Floor Construction
- Water Supply
- Compressed Air Supply
- Booth Cleaning Service
- Handling Fire and Dangerous Materials for Exhibits and Demonstration
- Carrying-in/Demonstration of Hydrogen
- Ceiling Construction

**Application Forms are available in the EXHIBITOR MANUAL -Application Forms-**

**● Regulations for Booth Construction**

1) **All stands must be furnished with at least decorations below.**

- Carpet
- Back & Side Walls (2.7m-3.6m height)
- Company Name Board

\*These decorations are not included in raw space charge.

\*If the booth is exposed to aisles on all four sides, back and side walls are not needed.

Yet, back wall(s) is(are) needed for the side which is not facing the aisle.

2) **The height limit of the stand (including decoration) is 3.6m (without setback). The walls must be built between the adjacent stands and they cannot be lower than 2.7m.**

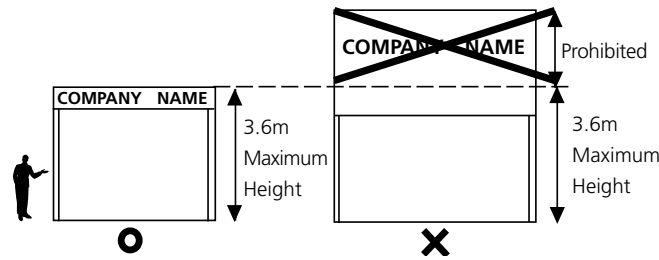

- a) All booth decoration and its associated equipment should be set below the height of 3.6m, including signboards, arches, floating objects (e.g. balloons) and plants for display.
- b) If your exhibits are higher than 3.6m, contact Show Management in advance.

3) **Stand construction is confined to the contracted stand space only.** Any signboards, arches, flags, furniture or exhibits should not protrude into the aisles nor extend beyond the contracted space. It is also prohibited to spray any mist outside your booth. The carpet covering your booth should be limited to your contracted space.

This does not apply to:

- booth number plates and other materials distributed by Show Management
- lightings to illuminate Company Name Board

4) If your stand is higher than adjacent stands, you must paint or cover the rear surface of the portion with white wall paper or white panels. When the wall height is different from the adjacent stands, it is prohibited to place any letters including company name facing those stands within 1 meter from the adjacent wall.

5) When constructing a wall within 1 meter from the aisle, the wall **must always be kept open for 1/3 of the length or more on each side.**

This does not apply to:

- the wall facing the wall/pillar of the venue.
- the side walls of the booth which is located at the outermost of the venue.

Example of a corner booth with 2 open sides

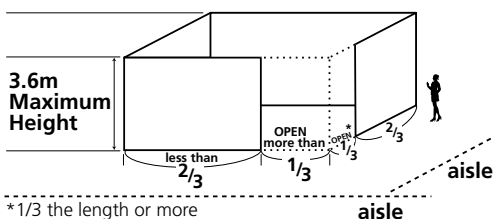

Example of a booth in between booths

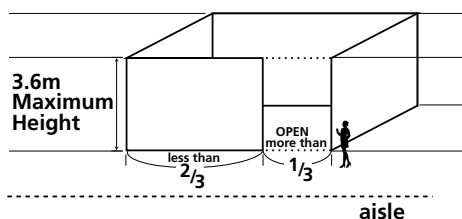

\*1/3 the length or more

### III. Regulations and Applications for Booth Construction

When a panel higher than 1m is constructed between the ground and 2.7m height as shown below, it will be considered as a wall. \*This does not apply to the part higher than 2.7m.

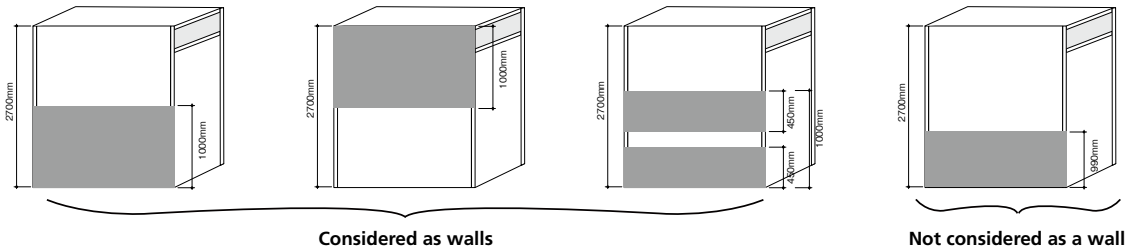

- 6) Hanging any decorative materials such as banners or wires from the ceiling of the exhibition halls is strictly prohibited.
- 7) If you plan to hold demonstrations or presentations in your booth, leave enough room for your audience to keep their attention inside your booth space.
- 8) **Two-story construction in the stand is strictly prohibited.** This rule applies to all types of construction including storage/stockroom, information counter, business meeting rooms, waiting rooms, etc. Construction of bridge or any kind of archway is also prohibited.
- 9) Carpet in the stand may only be laid using weak double-sided adhesive tape. Using glues or adhesive bonds is prohibited.
- 10) Any decorations or exhibits must not obstruct firefighting equipment and facilities, such as fire extinguishers, fire hydrants, sprinklers, emergency bells, emergency exit signs, etc. Also, exhibits should not be left unattended in these areas. Contact Show Management for the location of firefighting equipment.
- 11) Ceiling construction and shielding curtains are prohibited in principle. Any exhibitors planning to have a ceiling construction or shielding curtains are required to submit application for ceiling construction.
- 12) Take measures to strengthen the booth structure in order to prevent any collapse or damages from strong wind due to the opening/closing of shutter and iron door. Especially for the booths locates right beside the foundation wall of exhibition hall (there is no other booths between the foundation wall and your booth).  
Show Management will not be responsible for any damages of exhibits, accidents, injuries, trouble occurred due to the collapse of booth.  
Contact Show Management for inquiries regarding the distance between your booth and shutter/iron door.

## ● Inquiries Regarding PIT Plan

### 1. Request for PIT Plan

Contact: Person in Charge of PIT Plan, RX Japan  
E-mail: pit.jp@rxglobal.com

**This e-mail is for requesting PIT Plan ONLY.**

If you have other requests or inquiries, such as checking the details of booth decoration, please contact Show Management (Email: mwn\_support\_en.jp@rxglobal.com) directly.

### 2. Required Information

Please send the following information by e-mail.

- a) Exhibition: Show Title, Exhibition Venue
- b) Booth: Booth Number, Exhibitor Name
- c) Contact: Company Name, Person in charge, E-mail Address

### 3. Notice

- 1) PIT plan is available from 2 months before the exhibition. PIT plan is not ready for earlier inquiries.
- 2) PIT plan will be sent within 3 working days.
- 3) If you wish to install anchors or conduct floor construction, please refer to the page of "Floor Construction Regulations" and submit the application form required.
- 4) If the Show Title is not provided or the Exhibitor Name cannot be specified due to incomplete information, the PIT plan cannot be sent.

## ● Fire Regulations

Local fire officials will carry out inspections of the exhibition halls during move-in and show period. Fire officials have **final authority** on all safety and fire regulations, and have a right to order exhibitors **to remove any materials or to dismantle a booth if they do not comply with the fire regulations**. The Exhibition Venue is designated as a fireproof building, according to the eighth article of the fire laws. Therefore, please use anti-flammable decorations at the exhibition.

### 1) Panels for booth construction

**Panels or any wall materials** i.e. plywood board and printed plywood board, used for booth construction or for other furniture including decorations and reception counters, are **required to be soaked in an anti-flammable liquid in advance and should be labeled as anti-flammable accordingly**. Application of anti-flammable spray onsite will not be accepted as a proper procedure.

### 2) The use of fireproof materials

(I) Materials which have to be anti-flammable

- Accordion curtains or screens made of cloth, used for partition
- Hanging materials made of cloth, used for decoration on the wall
- Blinds made of cloth
- Curtains (all kinds of cloth curtains, drapes and blackout curtains, etc.)
- Screens for projectors
- Carpets, artificial lawns, mats
- Sheets

(II) Fireproof materials

- Nonflammable materials, prescribed in Article 2-9 of the Building Standard Act
- Quasi-nonflammable materials, prescribed in Article 1-5 of the Order for Enforcement of the Building Standard Act
- Plywood which is considered as a flame-retardant material, prescribed in Article 1-6 of the Order for Enforcement of the Building Standard Act

### 3) Anti-flammable label for each fireproof material

- The label must be attached at the most visible place.
- The label must be properly attached on the materials so that it does not come off easily.

### 4) Materials without fireproof capacity

Refrain from using plastic materials such as artificial flowers, urethane, acetate fiber, polyester, coolite or isolite, acrylic, nylon, etc. It is hard to apply fireproof finish to these materials.

### 5) Use of materials with domestic anti-flammable labels

- Foreign goods under the flame retardancy requirement, described as in 1) and 2) above, must have domestic anti-flammable labels in order to meet the domestic regulations.
- Foreign goods without anti-flammable labels must have the authorization from the Japanese qualifying activity.

### 6) Any actions that cause fire

Gas welding and any actions that cause fire are strictly prohibited unless pre-approved by the official contractor. Please note that you must contact the official contractor in advance, and must have a fire extinguisher in your booth when you use fire.

## ● Notes and Precautions

- 1) Due to the actual location of electrical pit in the venue, the electric cable may not be possible to be arranged to an unnoticeable location inside the booth. Contact the official contractor to confirm the location of electric mainline in advance before designing your booth.
- 2) Vehicles may be restricted temporarily from entering the exhibition halls for purpose of safety and adjustments. Please also note that vehicles may be required to wait outside.
- 3) Exhibitors must not damage or alter in any way the exhibition facilities, including electrical lines, lights, water facilities, stand decorations or exhibits of other exhibitors. In case of damage, exhibitors must return any damaged objects to their original state regardless of any reasons.
- 4) It is not allowed to paint directly on the pillars, or stick posters with adhesives or adhesive tapes. Building panels around the pillar or covering it with cloth without using adhesives are permitted. There may be fire extinguishers by the pillar. In such cases, please be sure they are not covered or hid away. For details, please contact Show Management in advance.
- 5) In case of using a drum-type cord reel, be sure to pull the wound cord completely off from the reel.
- 6) Booth construction and demolishing should be done inside your contracted space. No material is allowed to be left in the aisle or other space.
- 7) Redecorating your booth during the show period is prohibited.
- 8) There is no storage space in the exhibition halls. Prepare stock space in your own booth if necessary.

## ● Removal of Trash

Exhibitors are responsible for the removal of all trash. Any items including catalogues, books, etc. remaining in stands will be regarded as trash, and exhibitors will be charged for its removal. Contact the official contractor (refer to the list in the EXHIBITOR MANUAL –Application Forms–), if you request for cleaning service.

## ● No Smoking

Smoking in the exhibition halls, including inside your own booth, is strictly prohibited.

---

\*About the Use of Personal Information

We are taking the utmost care with personal information. Please visit the following URL to see our company policy. <https://privacy.rxglobal.com/>

## ● Floor Construction Regulations

### 1. Installation of Hole-in-Anchors

1) Exhibitors planning to make hole-in-anchors should submit the detailed drawing including the style, the number and the location of the anchors to the official contractor. If you wish to change the number of anchor bolts (including not to install any) after your application, please submit the application again by noon on the day before the show. No change is accepted after the exhibition. Anchor bolts installed without application may be charged.

The length of the hole-in-anchor should not exceed 60mm in length and 16mm in diameter, as shown in the images below.

2) Actions listed below are strictly prohibited. In case of violation, the exhibitor will be charged a penalty after the show.

- a) Installing hole-in-anchors onto pit covers and the atrium
- b) Using materials other than hole-in-anchors (concrete screw, nail, etc.)
- c) Using strong adhesive tape that damages the original state of the floor
- d) Coloring the floor
- e) Installing anchors within 200mm from the edge of the pit
- f) Using inside screw type anchor bolt
- g) Using anchor bolts other than "Strike Anchors"

\*Other kinds of anchor bolts including "Dropin Anchors", "Cut Anchors" and "Sleeve Anchors" are NOT acceptable.

### 2. Restorations of Original State

If anchor bolts protrude from the floor surface, do not pull them out but cut them off to restore the floor to its flat state.

Before cutting the anchor bolts, please ensure that there are no combustible materials nearby to prevent fires caused by sparks. It is recommended to wear protective goggles and long-sleeved flame-resistant work clothes to prevent injuries and burns.

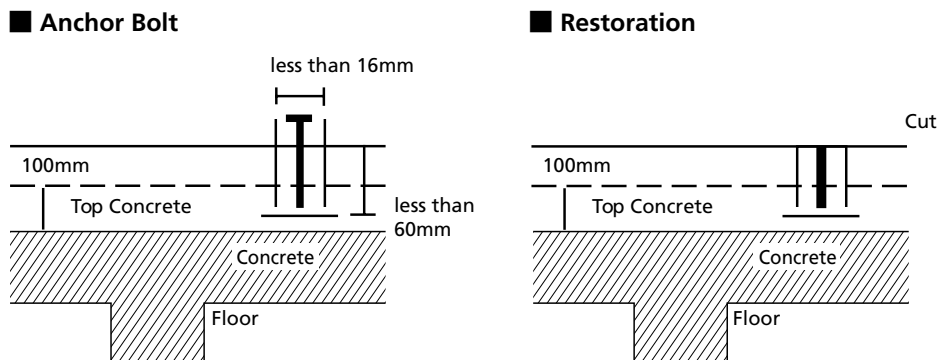

### 3. Requests for PIT Plan

Please refer to the page of "Inquiries Regarding PIT Plan" and contact RX Japan for PIT Plan.

## ● Electricity

Please submit the application for electrical service in your booth.

In case of using the Rental Display System, it is not required to submit this form.

If you need extra lighting for Rental Display System, please submit application.

- Submission after the deadline will incur an additional charge of JPY33,000(tax included) as redesign fee. Also submitted application without electric capacity or the location of main switch box will be incurred JPY33,000(tax included) redesign fee too.
- On-site power capacity modification or On-site breaker relocation will also incur JPY33,000(tax included).

Please contact the official electrical contractor by 3 weeks before the last day of the show, if you need to use electricity in your booth before the supply hours for machine adjustment or trial runs.

The fee is JPY 66,000 (tax included) per company.

Please note that applications submitted after the deadline will not be accepted.

## ● Water Supply

**Specification** \*All prices include 10% consumption tax.

### < WATER SUPPLY >

**Standard Inlet:** 1/2 " or 3/4 "

**Standard Outlet:** 3/4 " to 2 "

**Hydraulic Pressure:** under 0.2MPa – 0.3MPa

**Cost:** JPY 78,650/unit for construction

\*Including maintenance fee but excluding connecting charge to your equipment  
Charge for use of water will be billed after the show.

### < SUPPLY HOURS >

**The 2nd day of move-in** ..... 1:00pm - 6:00pm

**The 1st day of the show** ..... 8:00am - the end of the show

**The 2nd day of the show** ..... 8:30am - the end of the show

**The last day of the show** ..... 8:30am - the end of the show

\*Water supply is not available before or after the above supply hours.

## ● Compressed Air Supply

**Specification** \*All prices include 10% consumption tax.

### < AIR PLUMBING >

**Standard Air Lines:** 1/2 " or 3/4 "

**Standard Air Supply:** 0.5MPa – 0.6MPa, 300 liter/min.

**Exceeding in 300 liter:** JPY 12,650/100 liter

**Cost:** JPY 82,500/unit

\*Including maintenance fee but excluding connecting charge to your equipment

### < SUPPLY HOURS >

**The 2nd day of move-in** ..... 1:00pm - 6:00pm

**The 1st day of the show** ..... 8:00am - the end of the show

**The 2nd day of the show** ..... 8:30am - the end of the show

**The last day of the show** ..... 8:30am - the end of the show

\*Contact the official contractor directly for early / late air supply or any other inquiries.

## ● Handling Fire and Dangerous Materials for Exhibits and Demonstration

### 1. Notification to the Fire Department and Application Guideline

- The use of products causing fire or smoke and the transportation of dangerous material are prohibited by fire regulations. Exhibitors who involve any of those activities are required an application in order to acquire special permission from the Fire Department.
- Local fire officials will carry out inspections on the move-in day and during show period. Fire officials have final authority on all safety and fire regulations, and please note that failure to comply with the fire safety regulations may lead to the removal of the incomplete construction.
- Please submit the following necessary documents to the official contractor : application form, three copies of the catalogue of each equipment (SDS/MSDS) and a stand layout with each equipment's installation position.
- If you do not receive any contact from the official contractor in one week after the application, please contact them to avoid any oversight.

### 2. Activities which require Permission

#### 1) The Use of Naked Flame

Naked Flame includes (a) materials which generate flames or sparks with the usage of gaseous, liquid and solid fuels, and equipment which its heating part is exposed, (b) equipment using electricity which its heating part is burning visibly (hotplate, hair dryer and oven is not included), and the heating part exposed may ignite when flammable materials meet the heating part (surface temperature is 400°C or above). The pedestal has to be covered with non-metallic and anti-flammable material. Moreover, the use of naked flame requires absolute stability with constant supervision. Smoking is prohibited in the entire exhibition hall except for designated areas outside the building.

#### 2) Handling and Storing of Dangerous Materials

Dangerous materials represent those are stated in the appendix of Fire Service Act. Bringing those materials into the venue without permission from the Fire Department is prohibited.

##### a. Petroleum (Class 4)

Petroleum No.1 (gasoline, lacquer, thinner, alcohol)

Petroleum No.2 (paraffin, light oil)

Petroleum No.3 (heavy oil, lubricant, diesel oil)

Petroleum No.4 (gear oil, animal/vegetable fat and oil)

##### b. High-pressure Gas

Compressed High-pressure Gas (e.g. Oxygen, Nitrogen, Acetylene, Carbon Dioxide)

\*It is strictly prohibited to bring propane gas or hydrogen into the venue. Please utilize gas distribution plant of the venue if propane is needed.

### 3. Precautions for Handling and Construction

- 1) Install appropriate and adequate fire extinguishing equipment.
- 2) The use of equipment which involves high consumption of energy is not acceptable.
- 3) Stabilize the piping work of dangerous material by anti-flammable materials.
- 4) Keep a safety distance between the dangerous material and fire, such as using shielding materials.
- 5) If booth construction or dismantling generates any spark, prepare fire extinguishing equipment and station staffs for supervision. Please be aware that smoking is prohibited in the exhibition halls.
- 6) Dangerous material which is not for demonstration should be displayed in different container. For example, use colored water to change the details of the container.
- 7) Please note that alcohol for cleaning machines is also considered as dangerous material.

## ● Carrying-in/Demonstration of Hydrogen

Carrying in hydrogen and demonstration of products using hydrogen are prohibited in the exhibition halls. However, it is permitted if it fulfills the requirements of the fire regulations.

The deadline of application is earlier than in the past years according to the instructions of the Fire Department.

**Please submit the application form to the official contractor before the stated deadline. Any applications made after the deadline will not be guaranteed.**

\*If you do not receive any replies within a week after your application, please contact official contractor to avoid any oversight.

### 1. Application Procedures

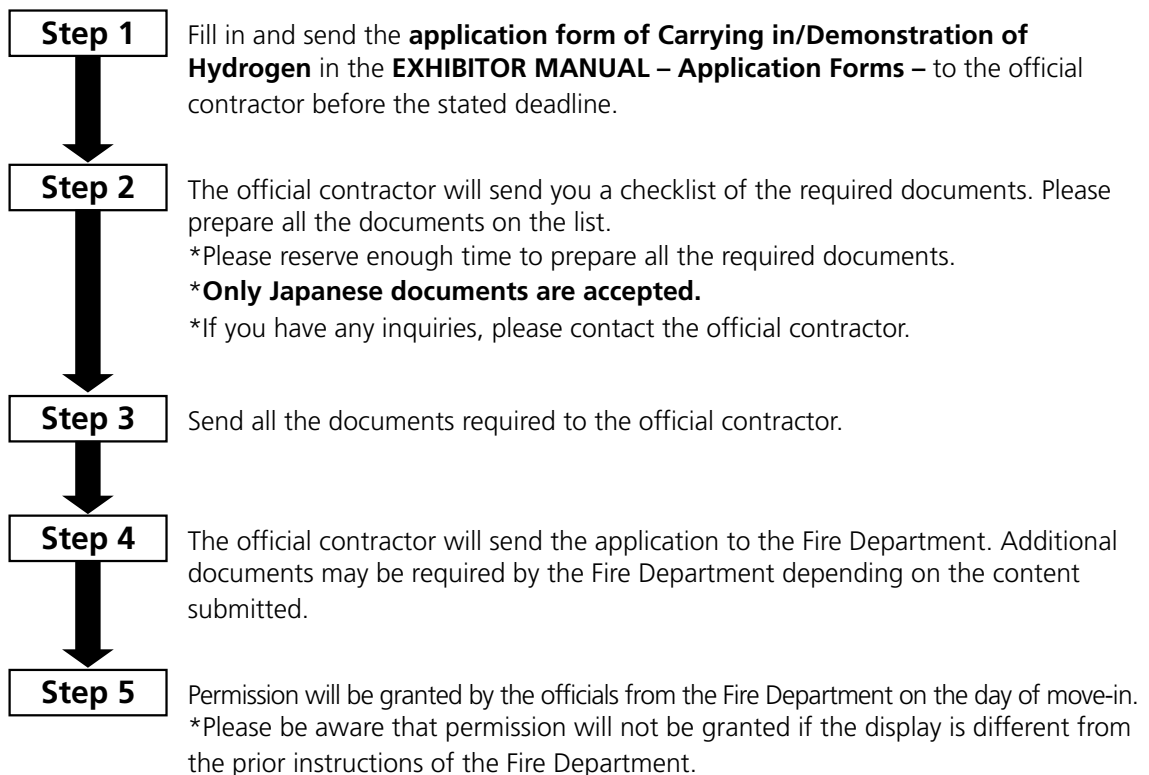

### 2. Caution

- (1) Application is required for carrying in hydrogen storage alloy according to the instructions of the Fire Department.
- (2) Only the minimum amount of hydrogen for daily usage is permitted for carrying in to the exhibition hall. Replenishment of hydrogen during the show period is not permitted.
- (3) Place fire extinguisher at the booth.
- (4) The person in charge for safety should be at the booth all the time, including the move-in period.
- (5) Only products approved in Japan are allowed to be used in demonstrations.
- (6) Inspections will be conducted strictly based on the Fire Prevention Ordinance.
- (7) Demonstrations may not be permitted if there is any incomplete document for application.

## ● Ceiling Structure

If you wish to carry out ceiling construction, please submit the following documents with the application form to the official contractor before the deadline.

- a) A plan and elevation of the booth decoration and an entire booth plan (indicate the location of the fire extinguisher, the area, materials and length of each side of the ceiling)
- b) A detailed drawing with written explanations of the ceiling construction (include the fire-proof label)

### **1. Ceiling Construction which Application is needed**

- a) Any ceilings which the length on one side is over 3m and the total area is over 20m<sup>2</sup>.
- b) Any ceilings (even if the area of ceiling is below 20m<sup>2</sup>) separated by hanging partitioned wall over 30cm.
- c) Installation of smoke detector is needed if the area of ceiling is larger than 1m<sup>2</sup> while the place is surrounded by walls or door on four sides. Yet, the following cases are not included.
  - Display area surrounded by non-flammable walls while it is not available for entry or exit of people
  - Exemption approved by the Fire Department

### **2. Principles and Conditions of Ceiling Construction**

- a) After submitting the layout of the booth and consulting with the Fire Department, the exhibitor is obligated to set fire-fighting facilities at the booth. (The exhibitor should bear the expenses of setting the fire-fighting facilities)
- b) Permission will be granted if a) is fully done and the inspection of Fire Department is passed. During the inspection, the inspector will ask for the details of the construction. The person in charge of ceiling construction have to be at the booth during the inspection in order to get the permission.
- c) If any violation is found or the permission of construction is not granted, the exhibitor should follow the instructions of Show Management to dismantle the ceiling and improve the decorations.
- d) Double ceiling is prohibited in any case.

Consultation with the Fire Department may take time.

Any applications submitted after the deadline will not be accepted.

#### ● Protection of Industrial Property Rights

1. The exhibitor is responsible for the protection of industrial property rights (patents, utility model rights, design rights and trademarks) of the products to be displayed at the exhibition. The exhibitor must take necessary actions such as patent applications, prior to participating in the exhibition.
2. The organisers of the exhibition are not responsible for protection of industrial property rights on exhibits.

#### ● About the Use of Personal Information

1. Show Management may release exhibitors' contact information on their behalf in the event that a global media service requests it for reporting on the tradeshow or one of Show Management's designated partner companies requests it for administrative matters related to exhibiting. Those not wishing to take advantage of this service are advised to contact Show Management.
2. We are taking the utmost care with personal information. Please visit the following URL to see our company policy. <https://privacy.rxglobal.com/>

# Details of Rental Display System

Wall panels, carpet, electricity, lights and furniture will not be included in the raw space. If you are not going to build a custom-made booth, you are recommended to use the rental display system.

100% of the total price (consumption tax included) will be charged if any cancellation of Rental Display System after a month before the first day of show occurs.

## Types and Handover of Rental Display System

Refer to the following pages for the types and prices of Rental Display System.

### **Type A & Type B**

- The booth will be ready by 10:00am on the second day of move in.
- A corner booth will have company name board(s) instead of wall panels on the side(s) facing the aisle(s).

### **Design Type**

- The booth will be ready by 1:00pm on the second day of move in.

## Notes

- The booth must be returned to its original condition of the rental display system.
- Any decorations to the walls and display tables that cannot be restored to their original conditions are prohibited, such as making holes with nails, screws and thumbtacks, painting on panels, leaving any posters or notices, and using tapes with strong adhesion.  
(Repairing cost will be charged for such acts, e.g., JPY 21,450/panel for back and side walls.)
- Items in the rental display system cannot be replaced nor exchanged with other items. They can be removed but the charges will not be reduced.

### **Type A & Type B**

- Any on-site orders for furniture that were previously cancelled through the advanced application will be considered additional orders. You will be charged the full cost for items ordered on-site, such as reordering a reception counter that was previously cancelled through the advanced application.
- Changing the height of the display tables on site will cause an additional charge of JPY 11,000.
- Changing the form of display tables on site, such as connecting and detaching multiple tables, will result in an additional charge of JPY 5,500 per 30 min to the exhibitor. Please request in advance.

### **Design Type**

- Changes or additional orders for furniture or items will incur extra charges. Please make sure to apply at least one month before the exhibition.
  - \*Refer to EXHIBITOR MANUAL – Application Forms – for more details of additional furniture.
  - \*On-site order of additional furniture is not accepted.
  - \*Contact the official electricity contractor for increasing the mainline power supply.

**Apply Rental Display System through Exhibitors Website.**

**If you have any additional requests, please contact the official contractors listed below.**

### **[Type A and Type B]**

- Changes of layout of lighting equipment or outlet: IIDA Electrical Works Co., Ltd.
- Changes of layout of other aspects: Sakura International Inc.

### **[Design Type]**

- Changes of layout or furniture: SHOEI BIJUTSU Co., Ltd.
- Additional lighting equipment or outlet: SHOEI BIJUTSU Co., Ltd.
- Increase the mainline power supply (e.g. 1kW → 2kW): IIDA Electrical Works Co., Ltd.

# Detail & Price

## Design Type

**4.5 Regular booth (9m × 8.1m) / JPY 2,610,000\***

\*10% consumption tax will be charged.

Contact



SHOEI BIJUTSU Co., Ltd.

Contact: Design Type Order Section

E-mail: [designtype2604@shoei-bijutsu.co.jp](mailto:designtype2604@shoei-bijutsu.co.jp)

\*The booth image may differ from the actual booth.



Round table will be provided if square table is out of stock.

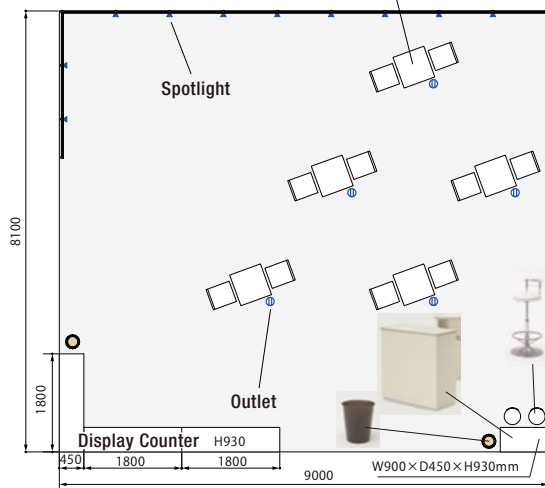

**Custom Plan**  
Choose 2 from A, B or C  
that best suits your  
exhibition purpose !

**A. Business Meeting Plan**



**B. Product Display Plan**

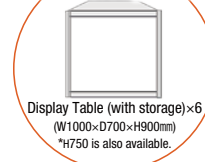

**C. Lead Acquisition Plan**



## Design Type / 4.5 Regular booth includes:

1	Side Panels	H2700 Color: White
2	Design Panel *Material: Fabric	2 Panels with Graphic Design (W8870×H2626mm × 1 / W2588×H2626mm × 1) Data of graphic Design need to be prepared by the exhibitor. You cannot set any shelves on the designed back panel. *Shelves can be set on side walls (at additional cost). *The size of panel may change depending on the shape of the booth.
3	Needle Punch Carpet	Color: Gray / Blue / Red / Ivory / Charcoal
4	Electricity/Lights	Spotlight with arm (LED15W) × 10, Outlet (100V up to 780W) × 5 Mainline power (100V up to 9kW) is included.
5	Furniture	Meeting Table Set × 5 (Table × 5, Chair × 10), Reception Counter × 1, Counter Chair × 2, Dustbin × 2, Display Counter × 3 Choose 2 from the following 3 types: A. Business Meeting Plan: Table (W600×D600×H650)×3, Chair×6 *Round table will be provided if square table is out of stock. B. Product Display Plan: Display Table (with storage) (W1000×D700×H900)×6 *H750 is also available. C. Lead Acquisition Plan: High Counter (W1800×D500×H1000)×3

(unit: mm)

# Design Type

**4 Regular booth (5.4m × 12m) / JPY 2,320,000\***

\*10% consumption tax will be charged.

Contact  
✉

SHOEI BIJUTSU Co., Ltd.

Contact: Design Type Order Section

E-mail: [designtype2604@shoei-bijutsu.co.jp](mailto:designtype2604@shoei-bijutsu.co.jp)

\*The booth image may differ from the actual booth.

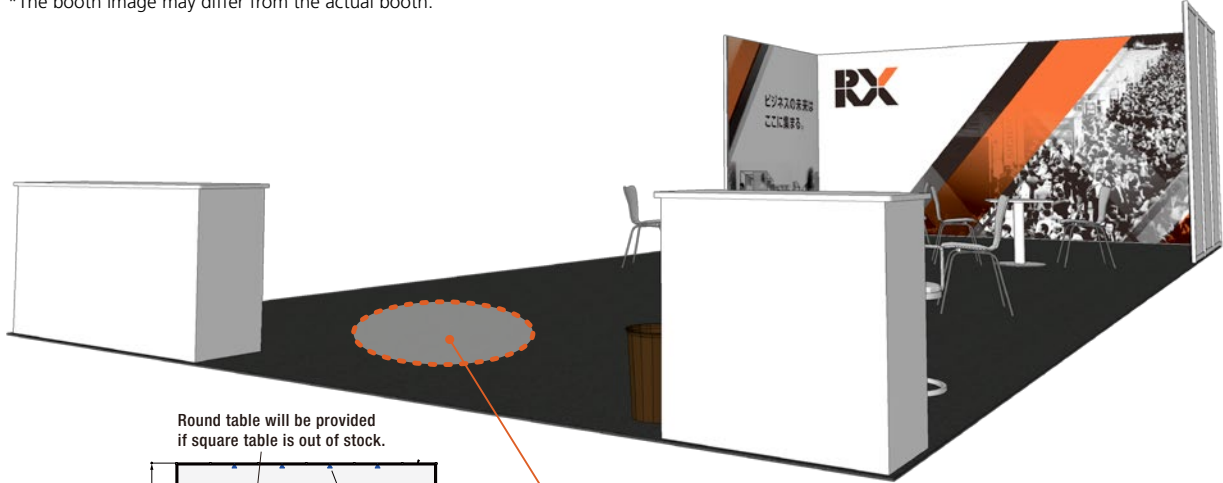

Round table will be provided if square table is out of stock.

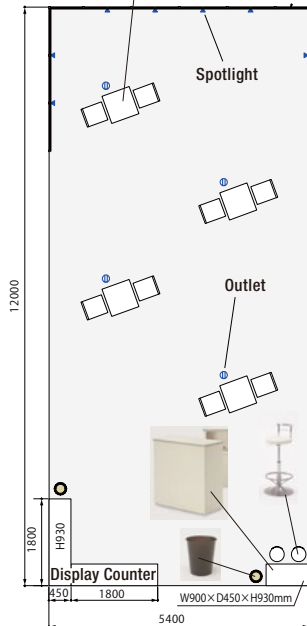

**Custom Plan**  
Choose 2 from A, B or C that best suits your exhibition purpose !

**A. Business Meeting Plan**



**B. Product Display Plan**

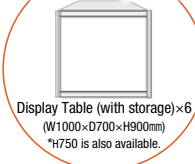

**C. Lead Acquisition Plan**



## Design Type / 4 Regular booth includes:

1	Side Panels	H2700 Color: White
2	Design Panel *Material: Fabric	2 Panels with Graphic Design (W5320×H2626mm × 1 / W2588×H2626mm × 1) Data of graphic Design need to be prepared by the exhibitor. You cannot set any shelves on the designed back panel. *Shelves can be set on side walls (at additional cost). *The size of panel may change depending on the shape of the booth.
3	Needle Punch Carpet	Color: Gray / Blue / Red / Ivory / Charcoal
4	Electricity/Lights	Spotlight with arm (LED15W) × 6-15, Outlet (100V up to 780W) × 4 Mainline power (100V up to 8kW) is included.
5	Furniture	Meeting Table Set × 4 (Table × 4, Chair × 8), Reception Counter × 1, Counter Chair × 2, Dustbin × 2, Display Counter × 2 Choose 2 from the following 3 types: A. Business Meeting Plan: Table (W600×D600×H650)×3, Chair×6 *Round table will be provided if square table is out of stock. B. Product Display Plan: Display Table (with storage) (W1000×D700×H900)×6 *H750 is also available. C. Lead Acquisition Plan: High Counter (W1800×D500×H1000)×3

(unit: mm)

# Design Type

**3 Regular booth (9m × 5.4m) / JPY 1,740,000\***

\*10% consumption tax will be charged.

Contact



SHOEI BIJUTSU Co., Ltd.

Contact: Design Type Order Section

E-mail: [designtype2604@shoei-bijutsu.co.jp](mailto:designtype2604@shoei-bijutsu.co.jp)

\*The booth image may differ from the actual booth.

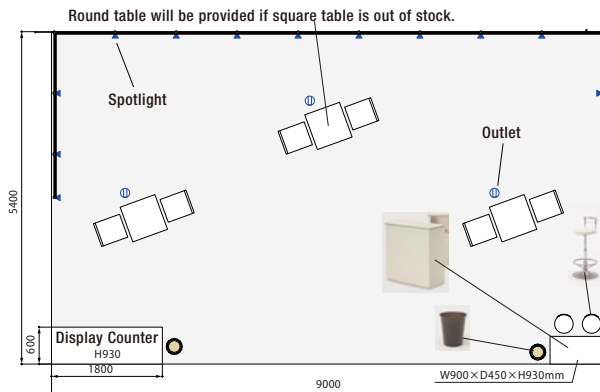

### Custom Plan

Choose 2 from A, B or C that best suits your exhibition purpose !

#### A. Business Meeting Plan



#### B. Product Display Plan

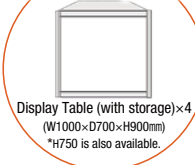

#### C. Lead Acquisition Plan



## Design Type / 3 Regular booth includes:

1	Side Panels	H2700 Color: White
2	Design Panel *Material: Fabric	2 Panels with Graphic Design (W8870×H2626mm × 1 / W2588×H2626mm × 1) Data of graphic Design need to be prepared by the exhibitor. You cannot set any shelves on the designed back panel. *Shelves can be set on side walls (at additional cost). *The size of panel may change depending on the shape of the booth.
3	Needle Punch Carpet	Color: Gray / Blue / Red / Ivory / Charcoal
4	Electricity/Lights	Spotlight with arm (LED15W) × 6-12, Outlet (100V up to 780W) × 3 Mainline power (100V up to 6kW) is included.
5	Furniture	Meeting Table Set × 3 (Table × 3, Chair × 6), Reception Counter × 1, Counter Chair × 2, Dustbin × 2, Display Counter × 1 Choose 2 from the following 3 types: A. Business Meeting Plan: Table (W600×D600×H650)×2, Chair×4 *Round table will be provided if square table is out of stock. B. Product Display Plan: Display Table (with storage) (W1000×D700×H900)×4 *H750 is also available. C. Lead Acquisition Plan: High Counter (W1800×D500×H1000)×2

(unit: mm)

# Type A

**3 Regular booths (9m × 5.4m) / JPY 1,740,000\***

\*10% consumption tax will be charged.

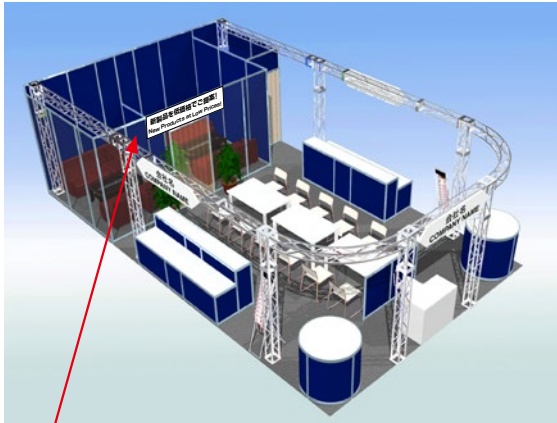

\*You can change the layout as you like.  
\*The booth image may differ from the actual booth.

**<Eye-catching Signboard (Additional Charge)>**

Put up your original Eye-catching Signboard to attract visitors' attention.

**新製品を低価格でご提案!**  
**New Products at Low Prices!**

<sample>

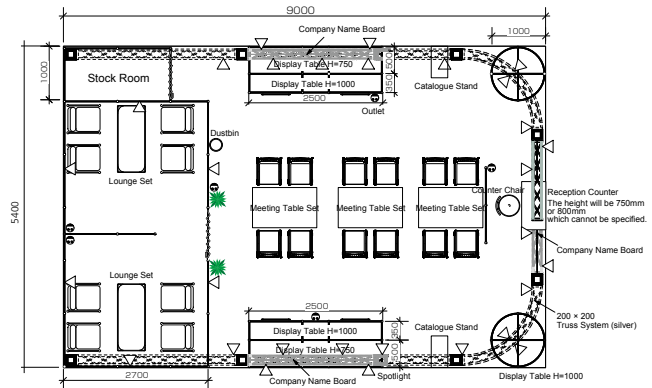

**Type A / 3 Regular booths include:**

1	Back & Side Walls	H2700 Color: White / Gray / Blue / Navy / Black / Green / Red *Default Color: White
2	Company Name Board	W1800 × H400 (both ends acute-angled) Color: White / Gray / Blue / Navy / Black / Red / Green / Vivid Green / Yellow / Pink *Default Color: White
3	Company Name Letters	Font: Gothic script Color: White / Black / Blue / Navy / Green / Red / Yellow *Default Color: Black
		The number of letters is unlimited (The size depends on the number of letters you register). *If your company name is not registered for the rental display system before the deadline, the company name your registered on the Exhibitors Website (Exhibitor Info) will be applied automatically. Please upload your logo image on the Exhibitors Website if you wish to use logo on the company name board.
4	Needle Punch Carpet	Color: Blue / Navy / Cream / Green / Gray / Red / Orange / Brown *Default Color: Gray
5	Electricity/Lights	Spotlight (LED15W) × 30, Outlet (100V up to 500W) × 6 Mainline power (100V up to 6kW) is included.
6	Furniture	Meeting Table Set × 3 (Table × 3, Chair × 12), Lounge Set × 2 (Table × 2, Sofa Set × 4) Reception Counter × 1, Counter Chair × 1, Catalogue Stand (12 shelves) × 2, Dustbin × 1, Plant × 2
7	Display Table (with storage)	1.2-level type × 2 (Front: W2500 × D500 × H750 + Back: W2500 × D350 × H1000) *Splittable: front and back / by W1000 when requested beforehand. *The color is same as the walls (except for the top panel) 2. Round type (ø1000 × H1000) × 2 *With No Storage *The color is same as the walls (except for the top panel).

\*If no information is registered for the rental display system before the deadline, default colors will be used for the company name board (including letters), wall panels and carpet. (unit: mm)

**<OPTIONAL> Additional Charge**

Eye-catching Signboard	Signboard (two-line): W1800 × H450 <b>JPY 7,000*/signboard</b> Signboard (one-line): W1800 × H300 <b>JPY 5,000*/signboard</b> Order via Exhibitors Website. The color choices are available on the online form.
------------------------	---

\*10% consumption tax will be charged.

## Type B

**3 Regular booths (9m × 5.4m) / JPY 1,320,000\***

\*10% consumption tax will be charged.

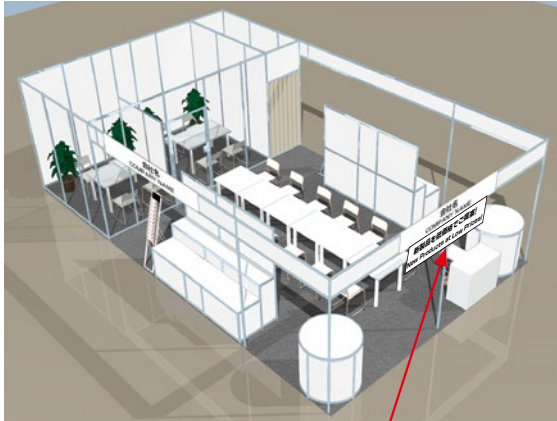

\*You can change the layout as you like.  
\*The booth image may differ from the actual booth.

**<Eye-catching Signboard (Additional Charge)>**

Put up your original Eye-catching Signboard to attract visitors' attention.

**新製品を低価格でご提案!**  
**New Products at Low Prices!**

<sample>

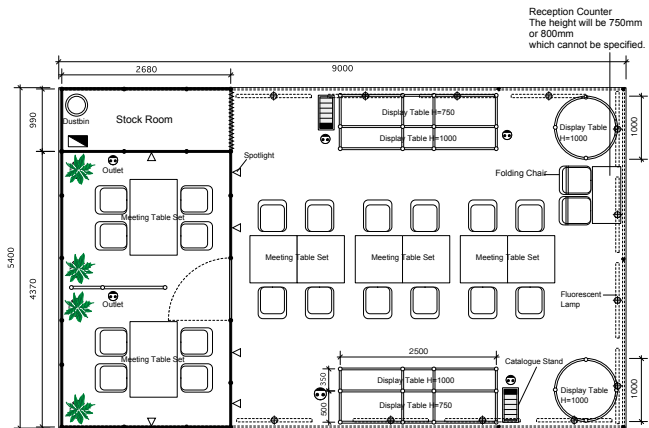

### Type B / 2 Regular booths include:

1	Back & Side Walls	H2700 Color: White
2	Company Name Board	W2400 × H400 Styrene Board Color: White / Blue / Black / Red / Navy *Default Color: White
3	Company Name Letters	Font: Gothic script
		<b>Black</b> when Company Name Board is White <b>White</b> when Company Name Board is Blue / Black / Red / Navy *Default Color: Black
		The number of letters is unlimited (The size depends on the number of letters you register). *If your company name is not registered for the rental display system before the deadline, the company name your registered on the Exhibitors Website (Exhibitor Info) will be applied automatically.
4	Needle Punch Carpet	Color: Gray / Red / Blue / Ivory / Charcoal *Default Color: Gray
5	Electricity/Lights	Spotlight (LED15W) × 6, Fluorescent Lamp (40W) × 12, Outlet (100V up to 780W) × 6, Mainline power (100V up to 6kW) is included.
6	Furniture	Meeting Table Set (Table × 1, Chair × 2) × 6 + (Table × 1, Chair × 4) × 2 Reception Counter × 1, Folding Chair × 2, Catalogue Stand (12 shelves) × 2, Dustbin × 1, Plant × 4
7	Display Table (with storage)	1. 2-level type × 2 (Front: W2500 × D500 × H750 + Back: W2500 × D350 × H1000) *Splittable: front and back / by W1000 when requested beforehand. 2. Round type (ø1000 × H1000) × 2 * With No Storage *The color is same as the walls (except for the top panel).

\*If no information is registered for the rental display system before the deadline, default colors will be used for the company name board (including letters), wall panels and carpet. (unit: mm)

**<OPTIONAL> Additional Charge**

Eye-catching Signboard	Signboard (two-line): W1800 × H450 <b>JPY 7,000*/signboard</b> Signboard (one-line): W1800 × H300 <b>JPY 5,000*/signboard</b> Order via Exhibitors Website. The color choices are available on the online form.
------------------------	---

\*10% consumption tax will be charged.

# Design Type

## 2 Regular booth (6m × 5.4m) / JPY 1,160,000\*

\*10% consumption tax will be charged.

Contact



SHOEI BIJUTSU Co., Ltd.

Contact: Design Type Order Section

E-mail: [designtype2604@shoei-bijutsu.co.jp](mailto:designtype2604@shoei-bijutsu.co.jp)

\*The booth image may differ from the actual booth.



Round table will be provided if square table is out of stock.

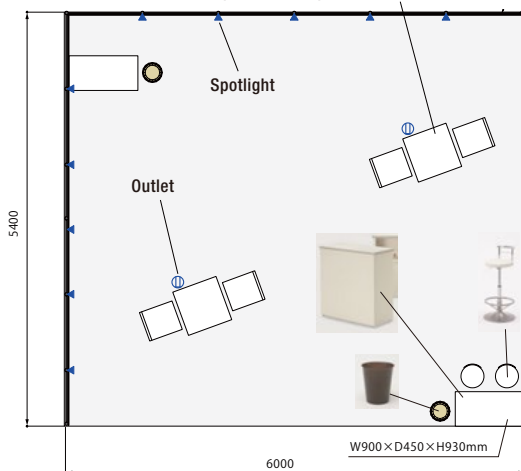

**Custom Plan**  
Choose 2 from A, B or C that best suits your exhibition purpose !

**A. Business Meeting Plan**



**B. Product Display Plan**

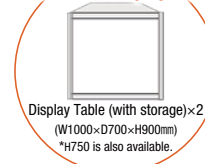

**C. Lead Acquisition Plan**



### Design Type / 2 Regular booth includes:

1	Side Panels	H2700 Color: White
2	Design Panel *Material: Fabric	2 Panels with Graphic Design (W5900×H2626mm ×1 / W5268×H2626mm ×1) Data of graphic Design need to be prepared by the exhibitor. You cannot set any shelves on the designed back panel. *Shelves can be set on side walls (at additional cost). *The size of panel may change depending on the shape of the booth.
3	Needle Punch Carpet	Color: Gray / Blue / Red / Ivory / Charcoal
4	Electricity/Lights	Spotlight with arm (LED15W) × 10, Outlet (100V up to 780W) × 2 Mainline power (100V up to 4kW) is included.
5	Furniture	Meeting Table Set × 2 (Table × 2, Chair × 4), Reception Counter × 2, Counter Chair × 2, Dustbin × 2 Choose 2 from the following 3 types: A. Business Meeting Plan: Table (W600×D600×H650)×1, Chair×2 *Round table will be provided if square table is out of stock. B. Product Display Plan: Display Table (with storage) (W1000×D700×H900)×2 *H750 is also available. C. Lead Acquisition Plan: High Counter (W1800×D500×H1000)×1

(unit: mm)

## Design Type Plus Monitor – 2 Regular booth (6m × 5.4m) / JPY 1,850,000\*

\*10% consumption tax will be charged.

Contact



SHOEI BIJUTSU Co., Ltd.

Contact: Design Type Order Section

E-mail: [designtype2604@shoei-bijutsu.co.jp](mailto:designtype2604@shoei-bijutsu.co.jp)

\*The booth image may differ from the actual booth.



Round table will be provided if square table is out of stock.

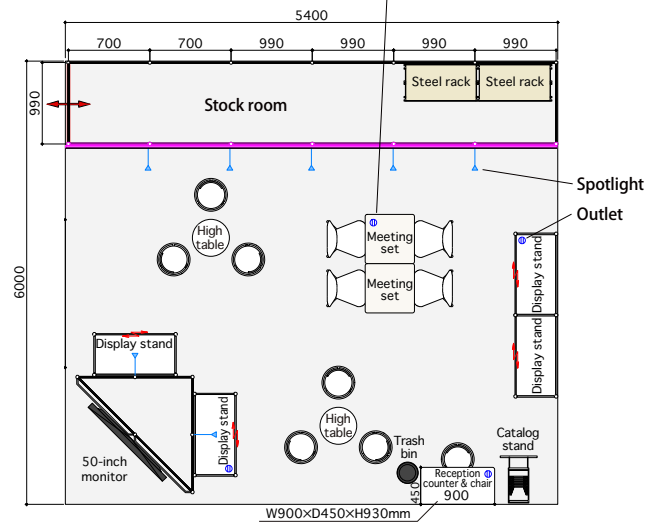

### Design Type Plus / Monitor - 2 Regular booth includes:

1	<b>Design Panel</b> *Material: Fabric	Back Panel with Graphic Design (W5400 × H2980mm) Data of graphic Design need to be prepared by the exhibitor. You cannot set any shelves on the designed back panel. *The size of panel may change depending on the shape of the booth.
2	<b>2 Triangle Panel (for Monitor Mounting)</b>	W2000×H2700×1, W1400×H2700 ×2 Color: White / Black / Gray
3	<b>Needle Punch Carpet</b>	Color: Gray / Blue / Red / Ivory / Charcoal
4	<b>Electricity/Lights</b>	Spotlight with arm (LED15W) × 7, Outlet (100V up to 780W) × 4 Mainline power (100V up to 4kW) is included.
5	<b>Furniture</b>	50-inch monitor (with mounting bracket) × 1 Meeting set (High table) × 2 sets (Table × 2, Chair × 6), Meeting set (Seated for 2) × 2 sets (Table × 2, Chair × 4), Display stand (W1000 × D500 × H900) × 4, Stock room (with door) × 1, Steel rack (4 shelves) × 2, Reception counter & chair × 1 set, Catalog stand × 1, Trash bin × 1

(unit: mm)

# Design Type Plus Panel – 2 Regular booth (6m × 5.4m) / JPY 1,650,000\*

\*10% consumption tax will be charged.

Contact



SHOEI BIJUTSU Co., Ltd.

Contact: Design Type Order Section

E-mail: [designtype2604@shoei-bijutsu.co.jp](mailto:designtype2604@shoei-bijutsu.co.jp)

\*The booth image may differ from the actual booth.

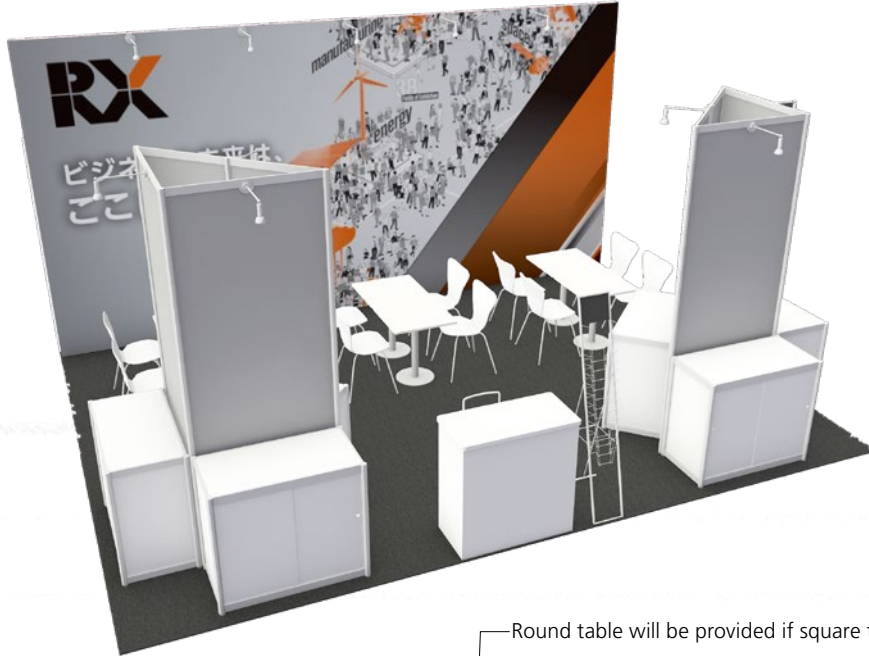

Round table will be provided if square table is out of stock.

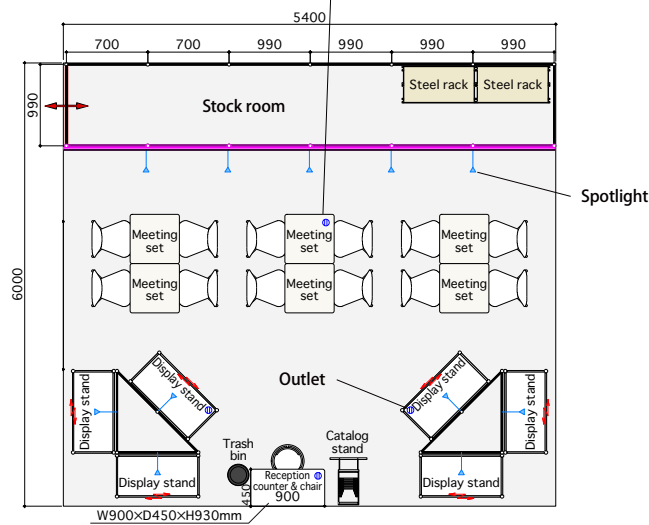

## Design Type Plus / Panel - 2 Regular booth includes:

1	<b>Design Panel</b> *Material: Fabric	Back Panel with Graphic Design (W5400 × H2980mm) Data of graphic Design need to be prepared by the exhibitor. You cannot set any shelves on the designed back panel. *The size of panel may change depending on the shape of the booth.
2	<b>2 Triangle Panel (for Monitor Mounting)</b>	W2000×H2700×1, W1400×H2700 ×2 Color: White / Black / Gray
3	<b>Needle Punch Carpet</b>	Color: Gray / Blue / Red / Ivory / Charcoal
4	<b>Electricity/Lights</b>	Spotlight with arm (LED15W) × 11, Outlet (100V up to 780W) × 4 Mainline power (100V up to 4kW) is included.
5	<b>Furniture</b>	Meeting set (Seated for 2) × 6 sets(Table × 6, Chair × 12), Display stand (W1000 × D500 × H900) × 6, Stock room (with door) × 1, Steel rack (4 shelves) × 2, Reception counter & chair × 1 set, Catalog stand × 1, Trash bin × 1

(unit: mm)

## Design Type Plus 2-Side Graphic – 2 Regular booth (6m × 5.4m) / JPY 1,650,000\*

\*10% consumption tax will be charged.

Contact



SHOEI BIJUTSU Co., Ltd.

Contact: Design Type Order Section

E-mail: [designtype2604@shoei-bijutsu.co.jp](mailto:designtype2604@shoei-bijutsu.co.jp)

\*The booth image may differ from the actual booth.

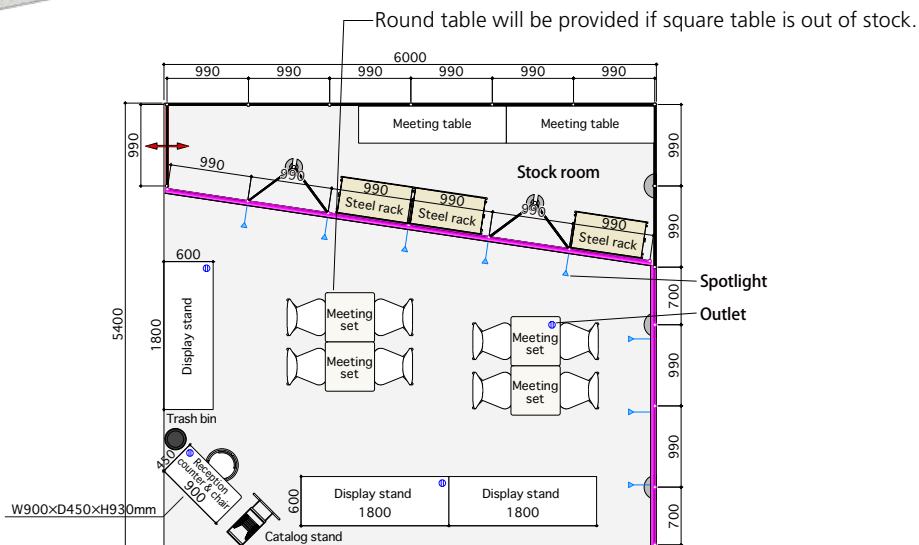

### Design Type Plus / 2-Side Graphic – 2 Regular booth includes:

1	<b>Design Panel</b> *Material: Fabric	2 Panels with Graphic Design (W5980×H2980mm ×1 / W3420×H2980mm×1) Data of graphic Design need to be prepared by the exhibitor. You cannot set any shelves on the designed back panel. *The size of panel may change depending on the shape of the booth.
2	<b>Needle Punch Carpet</b>	Color: Gray / Blue / Red / Ivory / Charcoal
3	<b>Electricity/Lights</b>	Spotlight with arm (LED15W) × 8, Outlet (100V up to 780W) × 4 Mainline power (100V up to 4kW) is included.
4	<b>Furniture</b>	Meeting set (Seated for 2) × 4 sets(Table × 4, Chair × 8), Display stand (W1800 × D600 × H900) × 3, Stock room (with door) × 1, Steel rack (4 shelves) × 3, Reception counter & chair × 1 set, Catalog stand × 1, Trash bin × 1

(unit: mm)

# Type A

**2 Regular booths (6m × 5.4m) / JPY 1,160,000\***

\*10% consumption tax will be charged.



<Sample>  
\*You can change the layout as you like.  
\*The booth image may differ from the actual booth.

< Optional Signboard for Exhibit Highlights >

**新製品を低価格でご提案!**  
**New Products at Low Prices!**

<Sample>

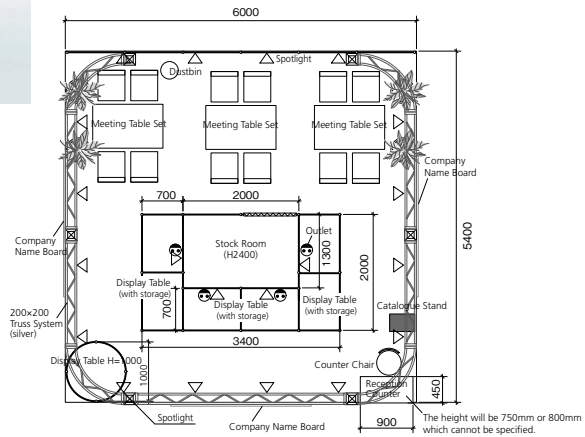

## Type A / 2 Regular booth includes:

1	Back & Side Walls	H2700 Color: White / Gray / Blue / Navy / Black / Green / Red *Default Color: White
2	Company Name Board	W1800 × H400 (both ends acute-angled) Color: White / Gray / Blue / Navy / Black / Red / Green / Vivid Green / Yellow / Pink *Default Color: White
3	Company Name Letters	Font: Gothic script Color: White / Black / Blue / Navy / Green / Red / Yellow *Default Color: Black The number of letters is unlimited (The size depends on the number of letters you register). *If your company name is not registered for the rental display system before the deadline, the company name your registered on the Exhibitors Website (Exhibitor Info) will be applied automatically.
4	Needle Punch Carpet	Color: Blue / Navy / Cream / Green / Gray / Red / Orange / Brown *Default Color: Gray
5	Electricity/Lights	Spotlight (LED15W) × 20, Outlet (100V up to 500W) × 4 Mainline power (100V up to 4kW) is included.
6	Furniture	Meeting Table Set × 3 (Table × 3, Chair × 12) Reception Counter × 1, Counter Chair × 1, Catalogue Stand (12 shelves) × 1, Plant × 4, Dustbin × 1
7	Display Table (with storage)	1. (W2000 × D700) × 3 *Choose H1000 or H750. Splittable by W1000 when requested beforehand. *The color is same as the walls (except for the top panel). 2. Round type (ø1000 × H1000) × 1 *No Storage *The color is same as the walls (except for the top panel).

\*If no information is registered for the rental display system before the deadline, default colors will be used for the company name board (including letters), wall panels and carpet.

(unit: mm)

### <OPTIONAL> Additional Charge

Eye-catching Signboard	Signboard (two-line): W1800 × H450 <b>JPY 7,000*/signboard</b> Signboard (one-line): W1800 × H300 <b>JPY 5,000*/signboard</b> Order via Exhibitors Website. The color choices are available on the online form.
------------------------	---

\*10% consumption tax will be charged.

## Type B

## 2 Regular booth (6m x 5.4m) / JPY 880,000\*

\*10% consumption tax will be charged.

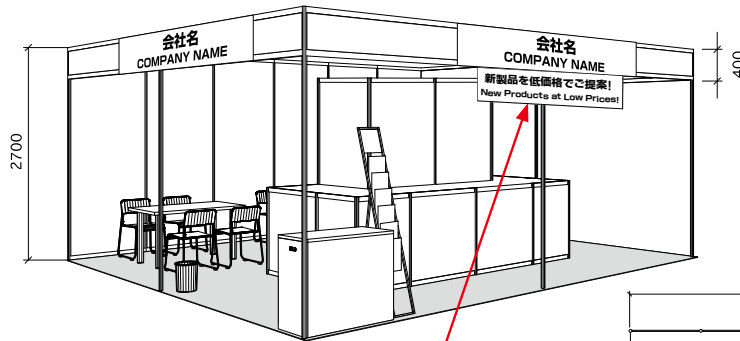

<Sample>

\*You can change the layout as you like.

\*The booth image may differ from the actual booth.

< Optional Signboard for Exhibit Highlights >

**新製品を低価格でご提案!**  
**New Products at Low Prices!**

<Sample>

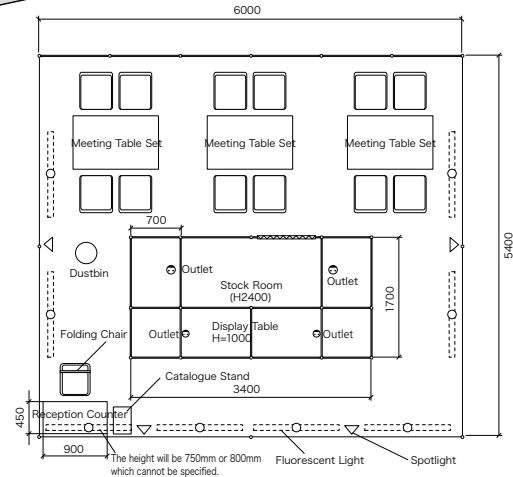

### Type B / 2 Regular booth includes:

1	Back & Side Walls	H2700 Color: White
2	Company Name Board	W2400 × H400 Styrene Board Color: White / Blue / Black / Red / Navy *Default Color: White
3	Company Name Letters	Font: Gothic script <b>Black</b> when Company Name Board is White <b>White</b> when Company Name Board is Blue / Black / Red / Navy *Default Color: Black The number of letters is unlimited (The size depends on the number of letters you register). *If your company name is not registered for the rental display system before the deadline, the company name your registered on the Exhibitors Website (Exhibitor Info) will be applied automatically.
4	Needle Punch Carpet	Color: Gray / Red / Blue / Ivory / Charcoal *Default Color: Gray
5	Electricity/Lights	Spotlight (LED15W) × 4, Fluorescent Lamp (40W) × 8, Outlet (100V up to 780W) × 4, Mainline power (100V up to 4kW) is included.
6	Furniture	Meeting Table Set × 3 (Table × 3, Chair × 12) Reception Counter × 1, Folding Chair × 1, Catalogue Stand (12 shelves) × 1, Dustbin × 1
7	Display Table (with storage)	1. (W1700 × D700) × 2 *Choose H1000 or H750. Splittable into W1000 and W700 when requested beforehand. 2. (W2000 × D700) × 1 *Choose H1000 or H750. Splittable by W1000 when requested beforehand.

(unit: mm)

\*If no information is registered for the rental display system before the deadline, default colors will be used for the company name board (including letters), wall panels and carpet.

### <OPTIONAL> Additional Charge

Eye-catching Signboard	Signboard (two-line): W1800 × H450 <b>JPY 7,000*/signboard</b>
	Signboard (one-line): W1800 × H300 <b>JPY 5,000*/signboard</b>

Order via Exhibitors Website. The color choices are available on the online form.

\*10% consumption tax will be charged.

## Design Type

**1.5 Regular booth (9m × 2.7m) / JPY 870,000\***

\*10% consumption tax will be charged.

Contact



SHOEI BIJUTSU Co., Ltd.

Contact: Design Type Order Section

E-mail: [designtype2604@shoei-bijutsu.co.jp](mailto:designtype2604@shoei-bijutsu.co.jp)

\*The booth image may differ from the actual booth.



### Custom Plan

Choose from: A: Business Meeting Plan / B: Product Display Plan / C: Lead Acquisition Plan

\*Plan A is used in the image above.

**+**  
Choose from A, B or C  
that best suits your  
exhibition purpose!

A. Business Meeting Plan



Table×2  
(W600×D600×H650mm)  
Chair×4

B. Product Display Plan



Display Table (with storage)×4  
(W1000×D700×H900mm)  
\*H750 is also available.

C. Lead Acquisition Plan



High Counter×2  
(W1800×D500×H1000mm)

Round table will be provided if square table is out of stock.

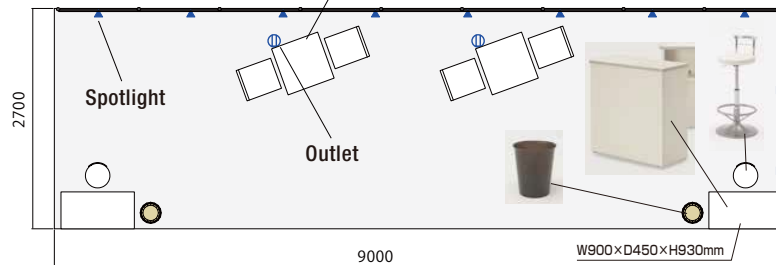

### Design Type / 1.5 Regular booth includes:

1	Side Panels	H2700 Color: White
2	Design Panel *Material: Fabric	Back Panel with Graphic Design (W8870mm x H2626mm) Data of graphic Design need to be prepared by the exhibitor. You cannot set any shelves on the designed back panel. *Shelves can be set on side walls (at additional cost).
3	Needle Punch Carpet	Color: Gray / Blue / Red / Ivory / Charcoal
4	Electricity/Lights	Spotlight with arm (LED15W) × 10, Outlet (100V up to 780W) × 2 Mainline power (100V up to 3kW) is included.
5	Furniture	Meeting Table Set × 2 (Table × 2, Chair × 4), Reception Counter × 2, Counter Chair × 2, Dustbin × 2  Choose 1 from the following 3 types: A. Business Meeting Plan: Table (W600×D600×H650)×2, Chair×4 *Round table will be provided if square table is out of stock. B. Product Display Plan: Display Table (with storage) (W1000×D700×H900)×4 *H750 is also available. C. Lead Acquisition Plan: High Counter (W1800×D500×H1000)×2

(unit: mm)

# Type A

**1.5 Regular booths (9m×2.7m) / JPY 870,000\***

\*10% consumption tax will be charged.



<Sample>  
 \*You can change the layout as you like.  
 \*The booth image may differ from the actual booth.

< **Optional** Signboard for Exhibit Highlights >

**新製品を低価格でご提案!**  
**New Products at Low Prices!**

<Sample>

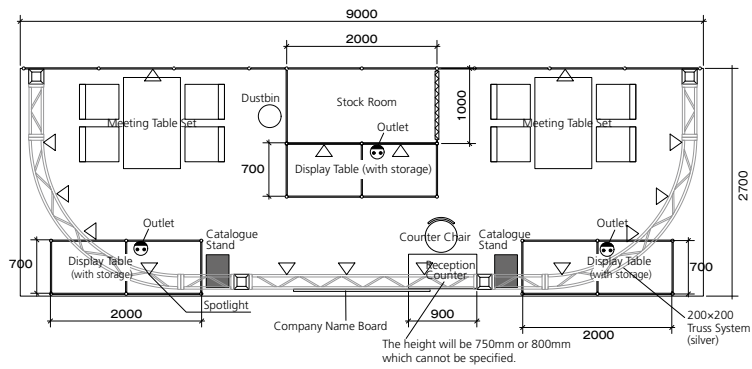

## Type A / 1.5 booth includes:

1	<b>Back &amp; Side Walls</b>	H2700 Color: White / Gray / Blue / Navy / Black / Green / Red *Default Color: White
2	<b>Company Name Board</b>	W1800 × H400 (both ends acute-angled) Color: White / Gray / Blue / Navy / Black / Red / Green / Vivid Green / Yellow / Pink *Default Color: White
3	<b>Company Name Letters</b>	Font: Gothic script Color: White / Black / Blue / Navy / Green / Red / Yellow *Default Color: Black The number of letters is unlimited (The size depends on the number of letters you register). *If your company name is not registered for the rental display system before the deadline, the company name your registered on the Exhibitors Website (Exhibitor Info) will be applied automatically.
4	<b>Needle Punch Carpet</b>	Color: Blue / Navy / Cream / Green / Gray / Red / Orange / Brown *Default Color: Gray
5	<b>Electricity/Lights</b>	Spotlight (LED15W) × 15, Outlet (100V up to 500W) × 3 Mainline power (100V up to 3kW) is included.
6	<b>Furniture</b>	Meeting Table Set × 2 (Table × 2, Chair × 8) Reception Counter × 1, Counter Chair × 1, Catalogue Stand (12 shelves) × 2, Dustbin × 1
7	<b>Display Table (with storage)</b>	(W2000 × D700) × 3 *Choose H1000 or H750. Splittable by W1000 when requested beforehand. *Color: Same color as your Back & Side Walls (except tabletop)

(unit: mm)

\*If no information is registered for the rental display system before the deadline, default colors will be used for the company name board (including letters), wall panels and carpet.

### <OPTIONAL> Additional Charge

<b>Eye-catching Signboard</b>	Signboard (two-line): W1800 × H450 <b>JPY 7,000*/signboard</b> Signboard (one-line): W1800 × H300 <b>JPY 5,000*/signboard</b> Order via Exhibitors Website. The color choices are available on the online form.
-------------------------------	---

\*10% consumption tax will be charged.

## Type B

1.5 Regular booth (9m×2.7m) / JPY 660,000\*

\*10% consumption tax will be charged.

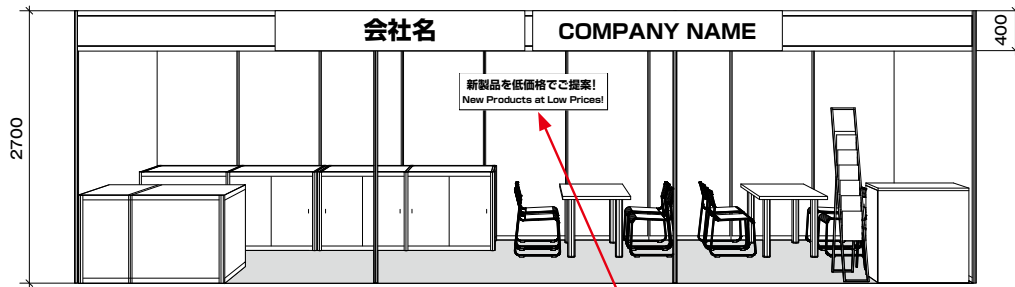

<Sample>

\*You can change the layout as you like.

\*The booth image may differ from the actual booth.

< Optional Signboard for Exhibit Highlights >

新製品を低価格でご提案!  
New Products at Low Prices!

<Sample>

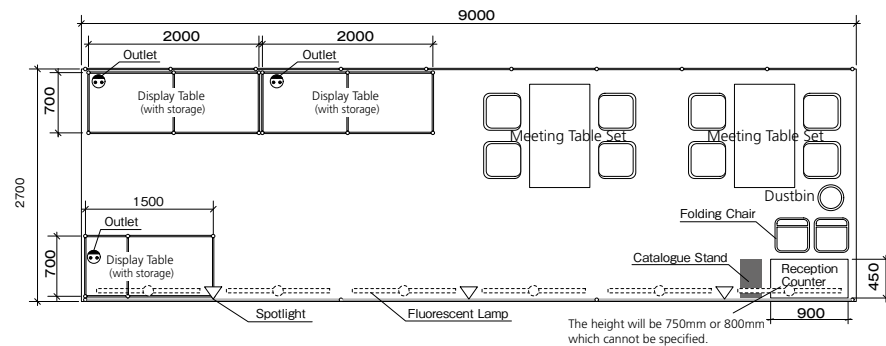

### Type B / 1.5 Regular booth includes:

1	Back & Side Walls	H2700 Color: White
2	Company Name Board	W2400 × H400 Styrene Board Color: White / Blue / Black / Red / Navy *Default Color: White
3	Company Name Letters	Font: Gothic script <b>Black</b> when Company Name Board is White <b>White</b> when Company Name Board is Blue / Black / Red / Navy *Default Color: Black
		The number of letters is unlimited (The size depends on the number of letters you register). *If your company name is not registered for the rental display system before the deadline, the company name your registered on the Exhibitors Website (Exhibitor Info) will be applied automatically.
4	Needle Punch Carpet	Color: Gray / Red / Blue / Ivory / Charcoal *Default Color: Gray
5	Electricity/Lights	Spotlight (LED15W) × 3, Fluorescent Lamp (40W) × 6, Outlet (100V up to 780W) × 3, Mainline power (100V up to 3kW) is included.
6	Furniture	Meeting Table Set × 2 (Table × 2, Chair × 8) Reception Counter × 1, Folding Chair × 2, Catalogue Stand (12 shelves) × 1, Dustbin × 1
7	Display Table (with storage)	1. (W2000 × D700) × 2 *Choose H1000 or H750. Splittable by W1000 when requested beforehand. 2. (W1500 × D700) × 1 *Choose H1000 or H750. Splittable into W1000 and W500 when requested beforehand.

\*If no information is registered for the rental display system before the deadline, default colors will be used for the company name board (including letters), wall panels and carpet. (unit: mm)

### <OPTIONAL> Additional Charge

Eye-catching Signboard	Signboard (two-line): W1800 × H450 <b>JPY 7,000*/signboard</b> Signboard (one-line): W1800 × H300 <b>JPY 5,000*/signboard</b> Order via Exhibitors Website. The color choices are available on the online form.
------------------------	---

\*10% consumption tax will be charged.

# Design Type

**1 Regular booth (6m × 2.7m) / JPY 580,000\***

\*10% consumption tax will be charged.

Contact



SHOEI BIJUTSU Co., Ltd.

Contact: Design Type Order Section

E-mail: [designtype2604@shoei-bijutsu.co.jp](mailto:designtype2604@shoei-bijutsu.co.jp)

\*The booth image may differ from the actual booth.

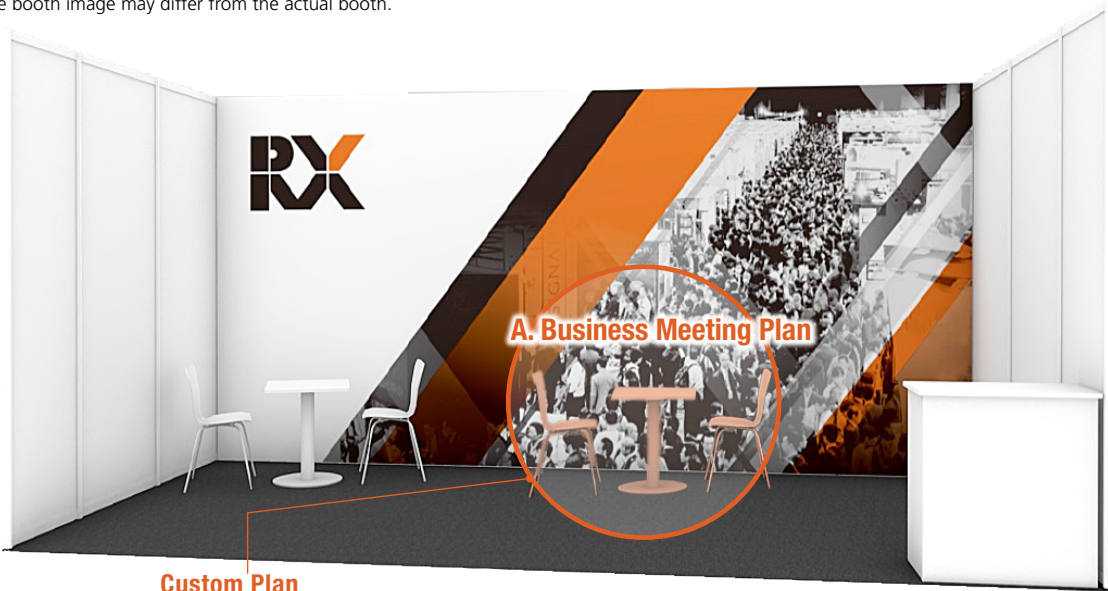

### Custom Plan

Choose from: A: Business Meeting Plan / B: Product Display Plan / C: Lead Acquisition Plan

\*Plan A is used in the image above.

Round table will be provided if square table is out of stock.

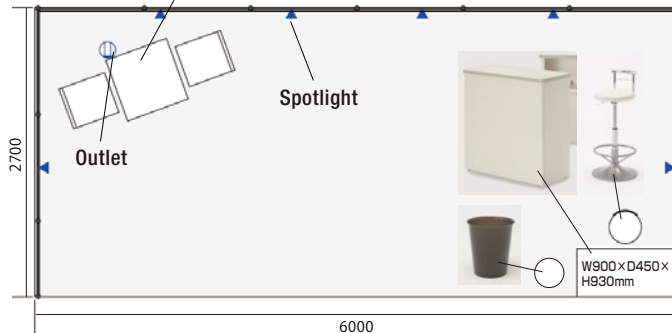

**+**  
Choose from A, B or C  
that best suits your  
exhibition purpose!

A. Business Meeting Plan



Table×1  
(W600×D600×H650mm)  
Chair×2

B. Product Display Plan

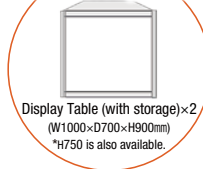

Display Table (with storage)×2  
(W1000×D700×H900mm)  
\*H750 is also available.

C. Lead Acquisition Plan



High Counter×1  
(W1800×D500×H1000mm)

## Design Type / 1 Regular booth includes:

1	Side Panels	H2700 Color: White
2	Design Panel *Material: Fabric	Back Panel with Graphic Design (W5900mm x H2626mm) Data of graphic Design need to be prepared by the exhibitor. You cannot set any shelves on the designed back panel. *Shelves can be set on side walls (at additional cost).
3	Needle Punch Carpet	Color: Gray / Blue / Red / Ivory / Charcoal
4	Electricity/Lights	Spotlight with arm (LED15W) × 6, Outlet (100V up to 780W) × 1 Mainline power (100V up to 2kW) is included.
5	Furniture	Meeting Table Set × 1 (Table × 1, Chair × 2), Reception Counter × 1, Counter Chair × 1, Dustbin × 1  Choose 1 from the following 3 types: A. Business Meeting Plan: Table (W600×D600×H650)×1, Chair×2 *Round table will be provided if square table is out of stock. B. Product Display Plan: Display Table (with storage) (W1000×D700×H900)×2 *H750 is also available. C. Lead Acquisition Plan: High Counter (W1800×D500×H1000)×1

(unit: mm)

# Type A

## 1 Regular booth (6m x 2.7m) / JPY 580,000\*

\*10% consumption tax will be charged.



<Sample>  
\*You can change the layout as you like.  
\*The booth image may differ from the actual booth.

< Optional Signboard for Exhibit Highlights >

**新製品を低価格でご提案!**  
**New Products at Low Prices!**

<Sample>

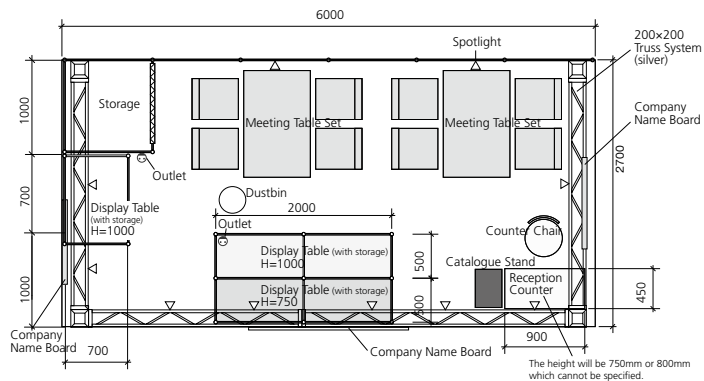

### Type A / 1 Regular booth includes:

1	Back & Side Walls	H2700 Color: White / Gray / Blue / Navy / Black / Green / Red *Default Color: White
2	Company Name Board	W1800 × H400 (both ends acute-angled) Color: White / Gray / Blue / Navy / Black / Red / Green / Vivid Green / Yellow / Pink *Default Color: White
3	Company Name Letters	Font: Gothic script Color: White / Black / Blue / Navy / Green / Red / Yellow *Default Color: Black The number of letters is unlimited (The size depends on the number of letters you register). *If your company name is not registered for the rental display system before the deadline, the company name you registered on the Exhibitors Website (Exhibitor Info) will be applied automatically.
4	Needle Punch Carpet	Color: Blue / Navy / Cream / Green / Gray / Red / Orange / Brown *Default Color: Gray
5	Electricity/Lights	Spotlight (LED15W) × 10, Outlet (100V up to 500W) × 2 Mainline power (100V up to 2kW) is included.
6	Furniture	Meeting Table Set × 2 (Table × 2, Chair × 8) Reception Counter × 1, Counter Chair × 1, Catalogue Stand (12 shelves) × 1, Dustbin × 1
7	Display Table (with storage)	1. (W1000 × D700 × H1000 or H750) × 1 *The color of the side of display tables is same as the walls. 2. 2-level type × 1 (Front: W2000 × D500 × H750 + Back: W2000 × D500 × H1000) *The color of the side of display tables is same as the walls. *Splittable by front and back / into W1000 when requested beforehand.

\*If no information is registered for the rental display system before the deadline, default colors will be used for the company name board (including letters), wall panels and carpet.

(unit: mm)

### <OPTIONAL> Additional Charge

Eye-catching Signboard	Signboard (two-line): W1800 × H450 <b>JPY 7,000*/signboard</b> Signboard (one-line): W1800 × H300 <b>JPY 5,000*/signboard</b> Order via Exhibitors Website. The color choices are available on the online form.
------------------------	---

\*10% consumption tax will be charged.

## Type B

## 1 Regular booth (6m x 2.7m) / JPY 440,000\*

\*10% consumption tax will be charged.

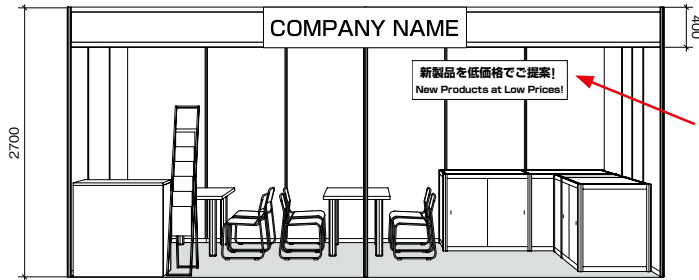

< Optional Signboard for Exhibit Highlights >

**新製品を低価格でご提案!**  
**New Products at Low Prices!**

<Sample>

<Sample>

\*You can change the layout as you like.

\*The booth image may differ from the actual booth.

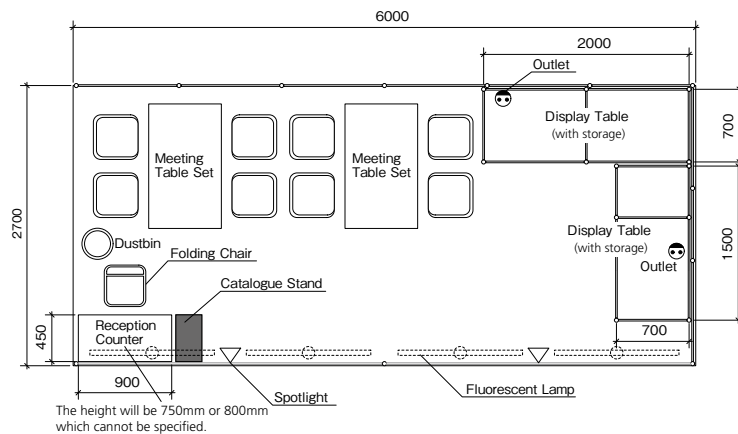

### Type B / 1 Regular booth includes:

1	Back & Side Walls	H2700 Color: White
2	Company Name Board	W2400 × H400 Styrene Board Color: White / Blue / Black / Red / Navy *Default Color: White
3	Company Name Letters	Font: Gothic script
		<b>Black</b> when Company Name Board is White <b>White</b> when Company Name Board is Blue / Black / Red / Navy *Default Color: Black
4	Needle Punch Carpet	Color: Gray / Red / Blue / Ivory / Charcoal *Default Color: Gray
5	Electricity/Lights	Spotlight (LED15W) × 2, Fluorescent Lamp (40W) × 4, Outlet (100V up to 780W) × 2, Mainline power (100V up to 2kW) is included.
6	Furniture	Meeting Table Set × 2 (Table × 2, Chair × 8) Reception Counter × 1, Folding Chair × 1, Catalogue Stand (12 shelves) × 1, Dustbin × 1
7	Display Table (with storage)	(W2000 × D700) × 1 *Choose H1000 or H750. Splittable by W1000 when requested beforehand. (W1500 × D700) × 1 *Choose H1000 or H750. Splittable into W1000 and W500 when requested beforehand.

\*If no information is registered for the rental display system before the deadline, default colors will be used for the company name board (including letters), wall panels and carpet.

(unit: mm)

### <OPTIONAL> Additional Charge

Eye-catching Signboard	Signboard (two-line): W1800 × H450 <b>JPY 7,000*/signboard</b> Signboard (one-line): W1800 × H300 <b>JPY 5,000*/signboard</b> Order via Exhibitors Website. The color choices are available on the online form.
------------------------	---

\*10% consumption tax will be charged.

# Design Type

**Mini booth (3m × 2.7m) / JPY 290,000\***

\*10% consumption tax will be charged.

Contact  
✉

SHOEI BIJUTSU Co., Ltd.

Contact: Design Type Order Section

E-mail: [designtype2604@shoei-bijutsu.co.jp](mailto:designtype2604@shoei-bijutsu.co.jp)

\*The booth image may differ from the actual booth.



**A. Business Meeting Plan**

**Custom Plan**

Choose from:

A: Business Meeting Plan

B: Product Display Plan

C: Lead Acquisition Plan

\*Plan A is used in the image on the right.

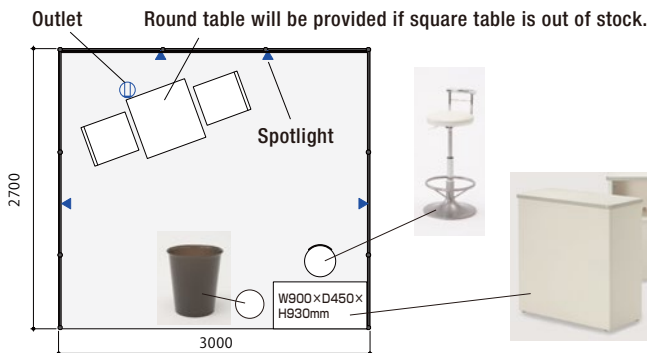

**+**  
Choose from A, B or C  
that best suits your  
exhibition purpose!

**A. Business Meeting Plan**



**B. Product Display Plan**

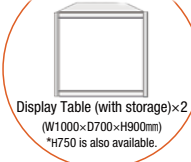

**C. Lead Acquisition Plan**



## Design Type / Mini booth includes:

1	Side Panels	H2700 Color: White
2	Design Panel *Material: Fabric	Back Panel with Graphic Design (W2930mm x H2626mm) Data of graphic Design need to be prepared by the exhibitor. You cannot set any shelves on the designed back panel. *Shelves can be set on side walls (at additional cost).
3	Needle Punch Carpet	Color: Gray / Blue / Red / Ivory / Charcoal
4	Electricity/Lights	Spotlight with arm (LED15W) × 4, Outlet (100V up to 780W) × 1 Mainline power (100V up to 1kW) is included.
5	Furniture	Meeting Table Set × 1 (Table × 1, Chair × 2), Reception Counter × 1, Counter Chair × 1, Dustbin × 1  Choose 1 from the following 3 types: A. Business Meeting Plan: Table (W600×D600×H650)×1, Chair×2 *Round table will be provided if square table is out of stock. B. Product Display Plan: Display Table (with storage) (W1000×D700×H900)×2 *H750 is also available. C. Lead Acquisition Plan: High Counter (W1800×D500×H1000)×1

(unit: mm)

# Type A

## Mini booth (3m x 2.7m) / JPY 290,000\*

\*10% consumption tax will be charged.



<Sample>  
 \*You can change the layout as you like.  
 \*The booth image may differ from the actual booth.

< Optional Signboard for Exhibit Highlights >

**新製品を低価格でご提案!**  
**New Products at Low Prices!**

<Sample>

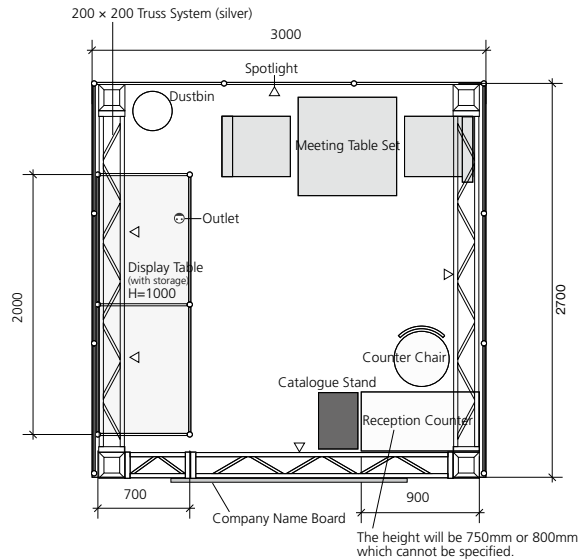

### Type A / Mini booth includes:

1	Back & Side Walls	H2700 Color: White / Gray / Blue / Navy / Black / Green / Red *Default Color: White
2	Company Name Board	W1800 x H400 (both ends acute-angled) Color: White / Gray / Blue / Navy / Black / Red / Green / Vivid Green / Yellow / Pink *Default Color: White
3	Company Name Letters	Font: Gothic script
		Color: White / Black / Blue / Navy / Green / Red / Yellow *Default Color: Black
4	Needle Punch Carpet	Color: Blue / Navy / Cream / Green / Gray / Red / Orange / Brown *Default Color: Gray
5	Electricity/Lights	Spotlight (LED15W) x 5, Outlet (100V up to 500W) x 1 Mainline power (100V up to 1kW) is included.
6	Furniture	Meeting Table Set x 1 (Table x 1, Chair x 2) Reception Counter x 1, Counter Chair x 1, Catalogue Stand (12 shelves) x 1, Dustbin x 1
7	Display Table (with storage)	(W2000 x D700) x 1 *Choose H1000 or H750. Splittable by W1000 when requested beforehand. *Color: Same color as your Back & Side Walls (except tabletop)

\*If exhibitors have not registered by the deadline of the rental display system, the default colors will be used for the company name board (including letters) and carpets.

(unit: mm)

### <OPTIONAL> Additional Charge

Eye-catching Signboard	Signboard (two-line): W1800 x H450 <b>JPY 7,000*/signboard</b> Signboard (one-line): W1800 x H300 <b>JPY 5,000*/signboard</b> Order via Exhibitors Website. The color choices are available on the online form.
------------------------	---

\*10% consumption tax will be charged.

## Type B

## Mini booth (3m x 2.7m) / JPY 220,000\*

\*10% consumption tax will be charged.

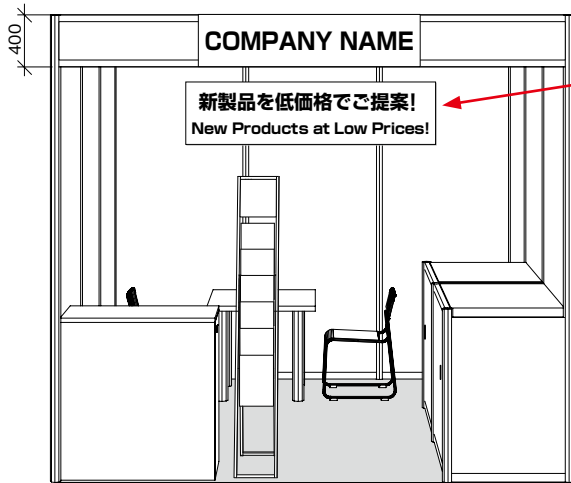

<Sample>

\*You can change the layout as you like.

\*The booth image may differ from the actual booth.

< Optional Signboard for Exhibit Highlights >

**新製品を低価格でご提案!**  
**New Products at Low Prices!**

<Sample>

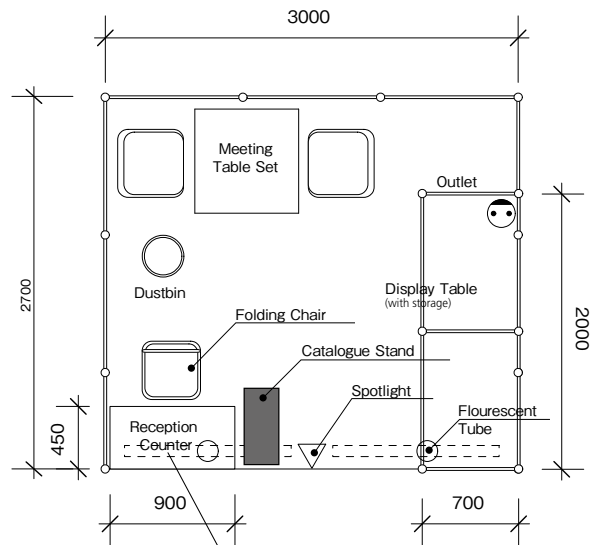

The height will be 750mm or 800mm which cannot be specified.

### Type B / Mini booth includes:

1	Back & Side Walls	H2700 Color: White
2	Company Name Board	W2400 × H400 Styrene Board Color: White / Blue / Black / Red / Navy *Default Color: White
3	Company Name Letters	Font: Gothic script <b>Black</b> when Company Name Board is White <b>White</b> when Company Name Board is Blue / Black / Red / Navy The number of letters is unlimited (The size depends on the number of letters you register). *If your company name is not registered for the rental display system before the deadline, the company name your registered on the Exhibitors Website (Exhibitor Info) will be applied automatically.
4	Needle Punch Carpet	Color: Gray / Red / Blue / Ivory / Charcoal *Default Color: Gray
5	Electricity/Lights	Spotlight (LED15W) × 1, Fluorescent Lamp (40W) × 2, Outlet (100V up to 780W) × 1, Mainline power (100V up to 1kW) is included.
6	Furniture	Meeting Table Set × 1 (Table × 1, Chair × 2) Reception Counter × 1, Folding Chair × 1, Catalogue Stand (12 shelves) × 1, Dustbin × 1
7	Display Table (with storage)	(W2000 × D700) × 1 *Choose H1000 or H750. Splittable by W1000 when requested beforehand.

\*If exhibitors have not registered by the deadline of the rental display system, the default colors will be used for the company name board (including letters) and carpets.

(unit: mm)

### <OPTIONAL> Additional Charge

Eye-catching Signboard	Signboard (two-line): W1800 × H450 <b>JPY 7,000*/signboard</b> Signboard (one-line): W1800 × H300 <b>JPY 5,000*/signboard</b> Order via Exhibitors Website. The color choices are available on the online form.
------------------------	---

\*10% consumption tax will be charged.

# Details of Rental Display System

## Panel Display Type / Pavilion Booth Type

Please contact Show Management for any inquiries regarding applications for the Panel Display Type or the Pavilion Booth Type.

### ● Pavilion Name Board

Please select one of the following options for the Pavilion Name Board:

- Prepare and submit the data yourself
- Request the Show Management to create it on your behalf



**Layout 1**  
Pavilion Name only (text)



**Layout 2**  
National flag + Pavilion Name



(Color: White / Blue / Black / Red / Navy)

### ● Types and Handover of Rental Display System

Refer to the following pages for the types and prices of Rental Display System.

- The booth will be ready by 1:00pm on the second day of move in.
- A corner booth will have company name board(s) instead of wall panels on the side(s) facing the aisle(s).

### ● Notes

\*The price below includes 10% consumption tax.

- The booth must be returned to its original condition of the rental display system.
- Any decorations to the walls and display tables that cannot be restored to their original conditions are prohibited, such as making holes with nails, screws and thumbtacks, painting on panels, leaving any posters or notices, and using tapes with strong adhesion.  
(Repairing cost will be charged for such acts, e.g., JPY 21,450/panel for back and side walls.)
- Items in the rental display system cannot be replaced nor exchanged with other items. They can be removed but the charges will not be reduced.
- Any on-site orders for furniture that were previously cancelled through the advanced application will be considered additional orders. You will be charged the full cost for items ordered on-site, such as reordering a reception counter that was previously cancelled through the advanced application.
- Changing the height of the display tables on site will cause an additional charge of JPY 11,000.
- Changing the form of display tables on site, such as connecting and detaching multiple tables, will result in an additional charge of JPY 5,500 per 30 min to the exhibitor. Please request in advance.

**If you have any additional requests, please contact the official contractors listed below.**

- Changes of layout of lighting equipment or outlet: IIDA Electrical Works Co., Ltd.
- Changes of layout of other aspects: Sakura International Inc.

# Panel Display Type

Available only for  
2 or larger booths

2 booth (6m×5.4m)  
With 4 exhibitors inside a pavilion  
**JPY 800,000**  
(tax not included) ~

## 2 booth(6m×5.4m) With 4 exhibitors inside a pavilion JPY 800,000(tax not included)

### Booth Image

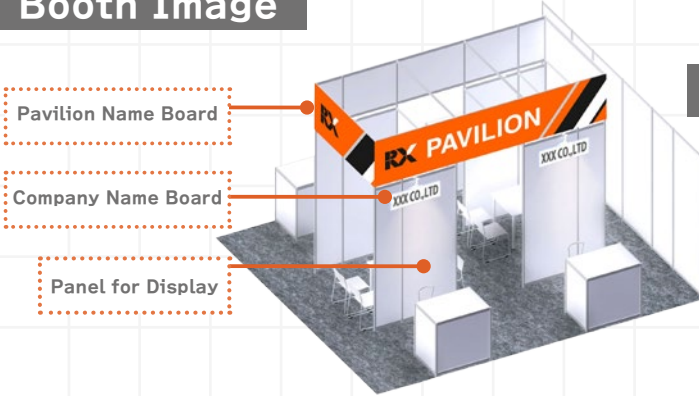

### Layout

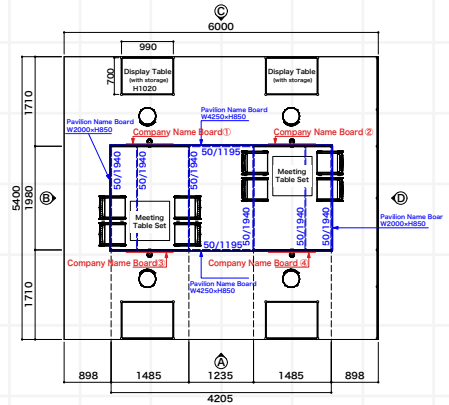

1	Pavilion Name Board	W4250×H850 x 2 · W2000×H850 x 2(Graphic Design)
2	Panel for Display	H2700(White) x 4
3	Company Name Board	W900×H300 x 4 Styrene Board Color: White / Blue / Black / Red / Navy *Default Color: White
4	Company Name Letters	Font: Gothic script Black when Company Name Board is White / White when Company Name Board is Blue / Black / Red / Navy The number of letters is unlimited (The size depends on the number of letters you register). * If your company name is not registered for the rental display system before the deadline, the company name your registered on the Exhibitors Website (Exhibitor Info) will be applied automatically.
5	Needle Punch Carpet	Color: Gray / Red / Blue / Ivory / Charcoal *Default Color: Gray
6	Electricity/Lights	Spotlight (LED15W) × 4, Outlet (100V up to 500W) × 4, Mainline power (100V up to 4kW) is included.
7	Furniture	Meeting Table Set × 2 (Table × 2, Chair × 8), Display Table (with storage)(W990×D700×H1000)×4 , Counter Chair × 4

(Unit: mm)

## 3 booth(9m×5.4m) With 6 exhibitors inside a pavilion JPY 800,000(tax not included)

### Booth Image

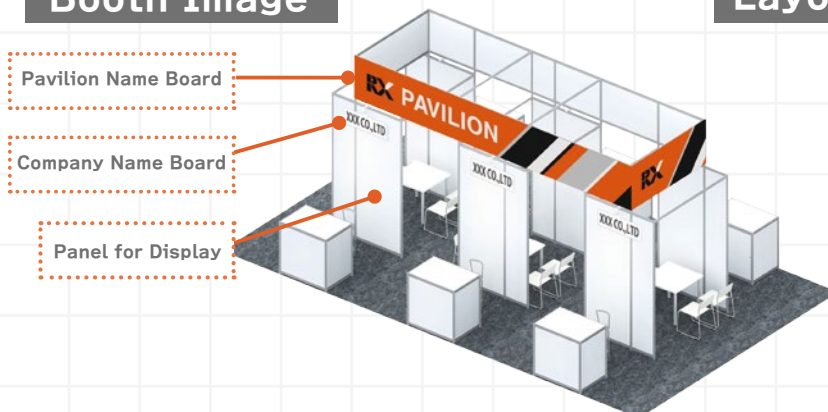

### Layout

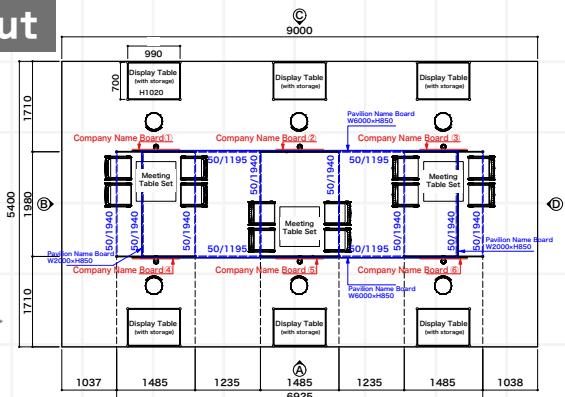

1	Pavilion Name Board	W6000×H850 x 2 · W2000×H850 x 2(Graphic Design)
2	Panel for Display	H2700(White) x 6
3	Company Name Board	W900×H300 x 6 Styrene Board Color: White / Blue / Black / Red / Navy *Default Color: White
4	Company Name Letters	Font: Gothic script Black when Company Name Board is White / White when Company Name Board is Blue / Black / Red / Navy The number of letters is unlimited (The size depends on the number of letters you register). * If your company name is not registered for the rental display system before the deadline, the company name your registered on the Exhibitors Website (Exhibitor Info) will be applied automatically.
5	Needle Punch Carpet	Color: Gray / Red / Blue / Ivory / Charcoal *Default Color: Gray
6	Electricity/Lights	Spotlight (LED15W) × 6, Outlet (100V up to 500W) × 6, Mainline power (100V up to 6kW) is included.
7	Furniture	Meeting Table Set × 3 (Table × 3, Chair × 12), Display Table (with storage)(W990×D700×H1000)×6 , Counter Chair × 6

(Unit: mm)

#### Notes:

- Panels for Display can be added. It costs JPY 50,000 + tax/panel.
  - No. of additional panels must be 2 or 4.
  - You cannot add 1 or 3 panels due to the structural reason.
  - Depending on the location and layout of your booth, you may not be able to apply.
- For further details, please contact Show Management

\*The booth image may differ from the actual booth.

\* If no information is registered for the rental display system before the deadline, default colors will be used for the company name board (including letters) and carpet.

# Pavilion Booth Type

0.5 booth (3m x 2.7m)  
**JPY 220,000**  
(tax not included)



You can separate Pavilion booths by the multiples of 0.5 booth.  
Furniture in each booth is the same as Rental Display System Type B.

- ex.)  
0.5 booth x 6 exhibitors = 3 booths
- 0.5 booth x 2 exhibitors + 1 booth x 2 exhibitors = 3 booths
- 0.5 booth x 2 exhibitors + 2 booths x 1 exhibitor = 3 booths

## Pavilion Booth Type 0.5 booth (3m×2.7m)

Layout

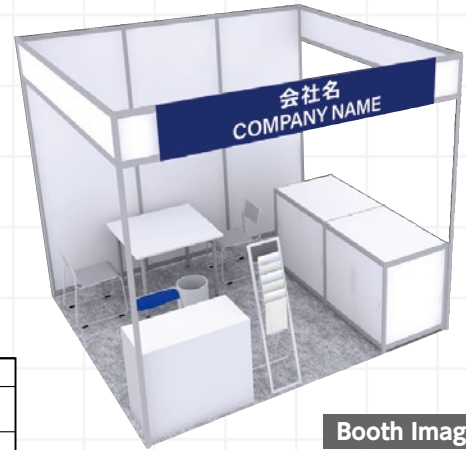
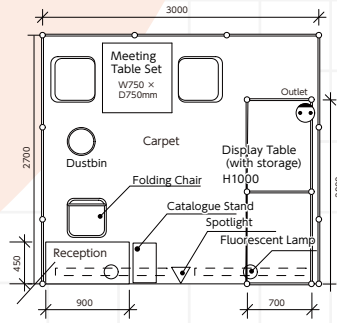

Booth Image

1	Back & Side Walls	H2700 Color: White
2	Company Name Board	W2400 x H400 Styrene Board Color: White / Blue / Black / Red / Navy *Default Color: White
3	Company Name Letters	Font: Gothic script Black when Company Name Board is White White when Company Name Board is Blue / Black / Red / Navy *Default Color: Black The number of letters is unlimited (The size depends on the number of letters you register). * If your company name is not registered for the rental display system before the deadline, the company name your registered on the Exhibitors Website (Exhibitor Info) will be applied automatically.
4	Needle Punch Carpet	Color: Gray / Red / Blue / Ivory / Charcoal *Default Color: Gray
5	Electricity/Lights	Spotlight (LED15W) x 1, Fluorescent Lamp (40W) x 2, Outlet (100V up to 780W) x 1, Mainline power (100V up to 1kW) is included.
6	Furniture	Meeting Table Set x 1 (Table x 1, Chair x 2), Reception Counter x 1, Folding Chair x 1, Catalogue Stand (12 shelves) x 1, Dustbin x 1
7	Display Table (with storage)	(W2000 x D700 x H1000 or H750) x 1 *Splittable by W1000 when requested beforehand.

\*Side panels (H2700) will be built when there is/are adjacent booth(s).  
\*The height of the reception counter will be 750mm or 800mm which cannot be specified.  
\*The booth image may differ from the actual booth.  
\* If no information is registered for the rental display system before the deadline, default colors will be used for the company name board (including letters), and carpet.

(Unit: mm)

## Pavilion Booth Type 1 booth (6m×2.7m)

Layout

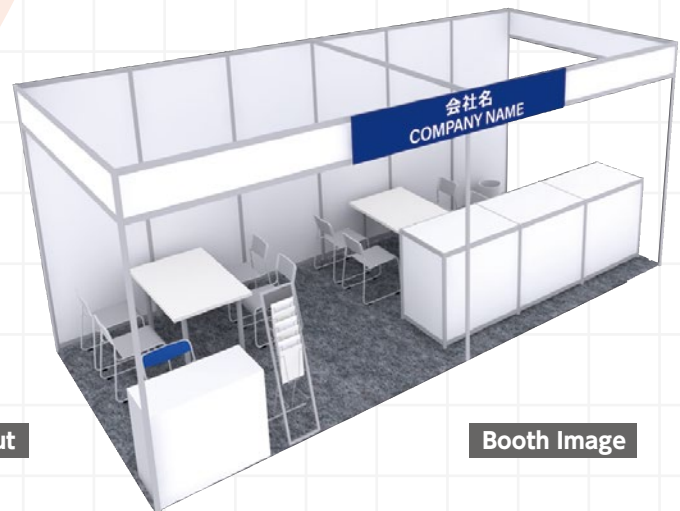
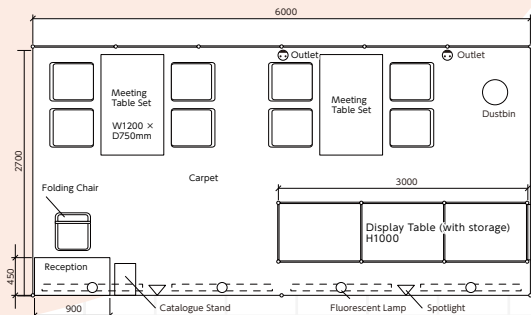

Booth Image

1	Back & Side Walls	H2700 Color: White
2	Company Name Board	W2400 x H400 Styrene Board Color: White / Blue / Black / Red / Navy *Default Color: White
3	Company Name Letters	Font: Gothic scrip Black when Company Name Board is White White when Company Name Board is Blue / Black / Red / Navy *Default Color: Black The number of letters is unlimited (The size depends on the number of letters you register). * If your company name is not registered for the rental display system before the deadline, the company name your registered on the Exhibitors Website (Exhibitor Info) will be applied automatically.
4	Needle Punch Carpet	Color: Gray / Red / Blue / Ivory / Charcoal *Default Color: Gray
5	Electricity/Lights	Spotlight (LED15W) x 2, Fluorescent Lamp (40W) x 4, Outlet (100V up to 780W) x 2, Mainline power (100V up to 2kW) is included.
6	Furniture	Meeting Table Set x 2 (Table x 2, Chair x 8), Reception Counter x 1, Folding Chair x 1, Catalogue Stand (12 shelves) x 1, Dustbin x 1
7	Display Table (with storage)	(W3000 x D700 x H1000 or H750) x 1 *Splittable by W1000 when requested beforehand.

\*Side panels (H2700) will be built when there is/are adjacent booth(s).  
\*The height of the reception counter will be 750mm or 800mm which cannot be specified.  
\*The booth image may differ from the actual booth.  
\* If no information is registered for the rental display system before the deadline, default colors will be used for the company name board (including letters), and carpet.

(Unit: mm)

### <OPTIONAL> Additional Charge Eye-catching Signboard

- Signboard (two-line) (W1800×H450mm) ...JPY7,000\*/signboard
- Signboard (one-line) (W1800×H300mm) ...JPY5,000\*/signboard

### Example <Two-line Signboard>

新製品を低価格でご提案!  
New Products at Low Prices!

(W1800×H450mm)

\*Please check the exhibitors website for colors of signboard, letters and character limits.